



Striving for Excellence

BAKING IS
ALWAYS
FUN AND
EFFORTLESS

BAKERY PRODUCT BROCHURE

www.janshaktiindia.com

PLANETARY MIXER-TABLE TOP

MODEL	SM-5L	SM-7L
Capacity(liter)	5	7
Agitator speed(rpm) 1st-10th	0-300	100-938
Power(kw)	0.32	0.35
Outside dimension(mm) (W*D*H)	234X389X400	231 X409X424
Weight(kg)	12	16
Standard attachment	bowl, beater, hook & whipping ball	



PLANETARY MIXER-TABLE TOP



5.0L PROFESSIONAL TILT HEAD STAND MIXER



7.0L PROFESSIONAL TILT HEAD STAND MIXER

MODEL	5.0L PROFESSIONAL	7.0L PROFESSIONAL
Wattage	800W	1500W
Motor Type	dc high torque motor	800W Dc High Torque Motor
Voltage	220-240v	220-240v
Frequency	50/60hz	50/60hz
Material Body	aluminium die-cats housing	Aluminium Die-cats Housing
Type Speed Control	manual rotating knob	Manual Rotating Knob
Dimensions Product	39cmx28cmx36cm	46cmx31cmx41cm
Functions	8 speeds manual speed control	Time & Countdown dough kneading function shuffling beating function fine mixing function rapid mixing function play - pause - restart
Max Capacity	1.00 kg all purpose flour 0.80 kg whole wheat flour 1l fresh cream 12 egg whites	2.25 kg flour 2l fresh cream 20 egg whites

PLANETARY MIXER MACHINE

MODEL	SM-101	SM-201	SM-401
Capacity(liter)	10	20	40
Agitator Speed(rpm)	148/307 /509	12712871534	105/208/404
1sU2nd/3rd speed			
Power(kw)	0.25	0.5	0.75
Outside Dimensio (mm) (W*D*H)	430X430X700	510X530X830	620X670X1000
Weight(kg)	60	94	170
Option	spiral hook	spiral hook	spiral hook



SPIRAL MIXER MACHINE

MODEL	SM2-25	SM2-50T
Capacity(kg) Flour	12.5	25
Capacity(kg) Dough	25	50
Spiral Power(kw)	2.2	3
Bowl Power(kw)	/	0.75
Spiral Speed(rpm) 1st Speed	140	135
Spiral Speed(rpm) 2nd Speed	280	270
Bowl Speed(rpm) 1st Speed	12.8	17.8
Bowl Speed(rpm) 2nd Speed	25.5	17.8
Weight(kg)	155	285
Outside Dimension(mm) (W*D*H)		



BREAD SLICER-TABLE TOP

MODEL	SM-302N
Motor Power(kw)	0.18
Weight(kg)	70
Max Dimension of Bread (mm) (Length)	360
Max Dimension of Bread (mm) (Height)	130
Outside Dimension(mm) (W*D*H)	556X720X720
Slicing Thickness	
standard 12mm, other thickness(9mm-48mm) can be customized	



DOUGH SHEETER HEAVY DUTY





MODEL	SM-630	SM-630E
Type	Floor Model	Floor Model
Working Width(mm)	585	500
Conveyor Table Length(mm)	1400	1000
Gap between Rollers(mm)	0.3-50	0.3-50
Machine tables are in working position(W*D*H)	3540X1040X1270	2540X950X1270
Machine tables are folded up (W*D*H)	2020X1040X1950	1250X950X1750
Power(kw)	0.75	0.75
Weight(kg)	272	234

DOUGH SHEETER



MODEL	SM2-520S	SM2-520F
Type	TABLE MODEL	TABLE MODEL
Working Width(mm)	500	500
Conveyor Table Length(mm)	670	980
Gap between Rollers(mm)	0.3-30	0.3-30
Machine tables are in working position(mm)	Width	1500
	Depth	950
	Height	580
Machine tables are folded up(mm)	Width	850
	Depth	950
	Height	670
Power(kw)	0.55	0.55
Weight(kg)	100	168

PROOFER

MODEL	SM-40SP	SM-32S
Capacity[number of trays]	40	32
Tray Size (mm)	400x600	400x600
Number of Shelves	20	16
Tray Layout		
Dimension(mm)W*D*H	725x1045x2115	725x945x1925
Weight(kg)	133	93
Door	Single Door	Single Door
Total Power(kw)	2	2.3
Control Mode	DIGITAL CONTROL PANEL	Mechanical Control Panel
Outside Panel	Stainless Steel With 30mm Pu Insulation	Stainless Steel Without Pu Insulation



CONVECTION OVEN- GAS & ELECTRICAL

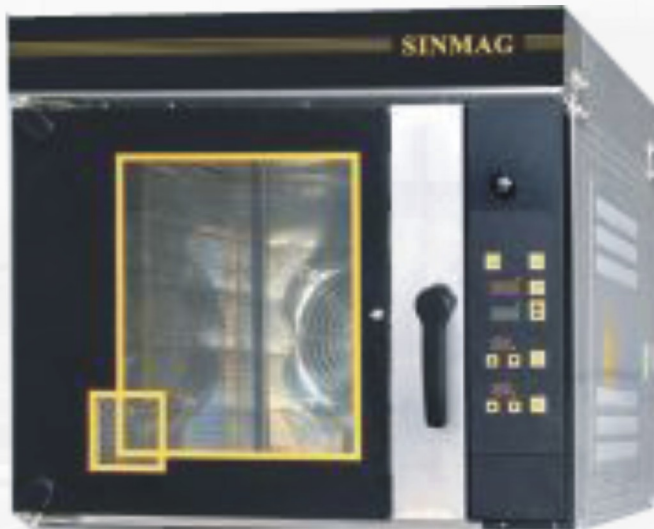

GAS TECHNICAL

ELECTRICAL TECHNICAL

MODEL	SM-705G	SM-710G	SM-705EE	SM-710EE
Capacity[number of trays]	5	10	5	10
Tray Size (mm)	400X600	400X600	400X600	400X600
Shelf Clearance[mm]	90	90	90	90
Dimension(mm)	Width	810	810	780
	Depth	1253	1253	1235
	Height	840	1390	690
Weight(kg)	210	270	159	270
Electric Power(kw)	0.5	1		
Total power			9.5	19
Thermal Output(kcal/h)	8730	17500		
Chamber Panel	stainless steel			
Outside Panel(front side)	stainless steel			
Outside Panel(other sides)	aluminum&zinc-coated steel			

DECK OVEN- GAS & ELECTRIC



GAS TECHNICAL

ELECTRICAL TECHNICAL

MODEL	SM-803T		SM2-523H
number of decks	3		3
number of trays(per deck)	3	2	2
tray size(mm)	400X600	460X760	400X600
tray layout			
external dimension(mm)	Width	1490	1320
	Depth	1150	1090
	Height	1755	1710
baking chamber dimension(mm)	Width	1020	1720
	Depth	805	720
	Height	240	230
weight(kg)	720		600
power per deck(kw)	0.14		5.5
max temperature(c)	300		300
Thermal Output per Deck (kcal/h)	8600		-

JANSHAKTI
Professional Kitchen Experts

Striving for Excellence

BRAND ASSOCIATED WITH US

SINMAG

salva

BUTLER®

SPAR MIXER®
SPAR

Kolb

Office & Showroom : 49, Chirag Diamond Estate, Beside Pushkar Business Park, Nr. D-Mart, Bapunagar, Ahmedabad-24, Gujarat (India). Email : sales@janshaktiindia.com

Works : Bakrol Bujrang, Ahmedabad, Gujarat 382433.

Experience Center : G.F. Shop No. 11 & 12, Swati Clover, Near Shilaj Circle, Beside Yanki Sizzlers, S.P. Ring Road, Thaltej, Ahmedabad, Gujarat 380054 (INDIA)

www.janshaktiindia.com

For more details : +91 95740 01797 / 92650 45532



Striving for Excellence

IMPORTED PRODUCT BROCHURE

FINEST PROFESSIONAL
IMPORTED KITCHEN
EQUIPMENT & SOLUTIONS

COMPANY OVERVIEW



Incorporated almost half a century ago, Janshakti Industries has since gone from being just a Kitchen Equipments Provider to a Total Commercial Kitchen Equipment manufacturer & solution provider company. Driven by the determination to serve the needs of the whole “HO-RE-CA” sector, “Janshakti Industries” has today become a synonym to “Trust”.

Over the time span Janshakti Industries had crafted numerous commercial kitchens qualifying satisfied results. Staying at par with latest demands and changing trends in the market, Janshakti Industries has always strived towards maximum satisfaction through innovative products and unmatched after sale services. Janshakti Industries is today fulfilling the demands of a wide range of consumers from HO- RE-CA sector, with its most advanced kitchen solutions. With finest of raw materials and the latest and innovative technologies Janshakti Industries is today manufacturing a range of diversified products which includes Preparation Machineries, Cooking Equipments, Working & Utility Tables, Fast Food Equipments, Deck Ovens, Bakery Equipments, Catering Equipments, Trolleys, Bain Marie, Dining Tables, Cold Equipments, Display & Counters Equipments, Wash Area Equipments, Dish Washers, L.P.G Gas Pipe Line Installation & Burner & Spares etc. With such an army of product range Janshakti Industries has always lived up to the expectations.



VISION

One Vision. One Team.

To be globally admired leader for planning, designing and producing finest professional kitchen equipments. We shall be known for our, Excellent Product Quality & Innovation, Wide service support and Quality of Operations.

MISSION

Where Purpose Transforms into a Mission.

Providing a value for money product & innovative ideas for professional kitchen solutions, that can create a benchmark in HO-RE-CA sector, for the local, national and international. To promote a dynamic work culture that encourages employees to demonstrate their best and promote the importance of ethics in their duties. To manufacture quality products that can live up to consumer's expectations.

Quality Statement

Quality is never an accident; it is always the result of high intention, sincere effort, intelligent direction and skillful execution; it represents the wise choice of many alternatives.

BRANDS ASSOCIATED WITH US



We
Work With...

HOSPITALITY CONSULTANTS

PMC'S

ARCHITECTS / INTERIORS

CATERING COMPANIES

CHEFS

HVAC CONSULTANTS

Visit our showroom



@BAPUNAGAR

VISIT OUR **SHOWROOM**
AND EXPERIENCE TO ENSURE THAT
YOU GET THE BEST IN CHOICE
INNOVATIVE PRODUCTS!!

Visit our Experience Center



**VISIT OUR EXCLUSIVE
EXPERIENCE CENTER
BEFORE STARTING YOUR DREAM KITCHEN PROJECT**

We will always be
happy to serve you

After Sales Service

Great after sales service is always top priority for our customers. For more than 45 years in the industry we had always stayed ahead of other by understanding clients need & providing excellent services.

JANSHAKTI INDUSTRIES is more likely recommended by our customers to others. We always take proud of that.

To provide services seamlessly, we do have dedicated after sales service number where team of professionals take care of the matter diligently. As company is growing dynamically, we are spreading our geographical boundaries of our technical team to provide faster services.

Give us call now ☎ +91 957400 1800

Timing 10.00 am - 7.00 pm

or write us at 📧 service@janshaktiindia.com

We are also offering
“Annual Maintenance Contract” & revolutionary
“Prepaid Service Scheme” with ultimate
on time approach with most economical prices.

Call now and get your AMC or PSS done.



INDEX

SIRMAN	01
ROBOT COUPE	04
SANTOS	08
SALVA	09
SPAR	11
UNOX	12
ALTO SHAAM	13
VITAMIX / HAMILTON BEACH	14
JTC / BUTLER	15
HATCO	16
MENUMASTER / BUTLER	18
HOSHIZAKI	19
ELANPRO	21
ICE-BOY	23
UGOLINI / TRUFOST	24
IFB	25
WINTERHALTER	26
WASHMATIC	27
MERRYCHEF	28
LINCOLN	30
CONVOTHERM	31
DEAN / FRYMASTER	33
BUTLER	34
IDEAL	35
ASTORIA	36
LA MARZOCCO	38
ANTUNES	39
ROLLER GRILL	40
CAMBRO	41
NAYATI	43
T&S	44

VEGETABLE-CUTTER

- Aluminium alloy and s/s construction.
- Ventilated motor for continuous operation.
- Thanks to its compact design the machine is easy to install inside every kitchen.
- The exclusive feeding system makes it easy to process also soft products like mozzarella cheese.
- Safe operation is ensured by interlock switches on product pusher, lid and collecting tray.
- Version with dishwasher safe S/S lid available.
- Large number of discs available for every purpose.

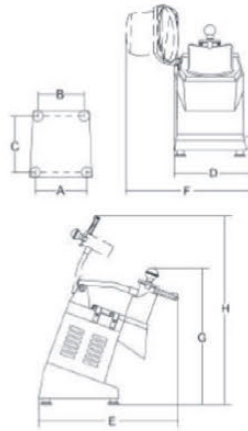

				(A)	(B)	(C)	(D)	(E)	(F)	(G)	(H)			
	watt/Hp	rpm	rpm	mm	mm	mm	mm	mm	mm	mm	mm	kg	mm	kg
TM Inox	515/0.7	1ph/3ph	300	225	195	225	280	510	400	510	770	18.5	750x350x500	22
TM All	515/0.7	1ph/3ph	300	225	195	225	280	510	400	510	770	18.5	720x350x500	22
TM-TG	515/0.7	1ph/3ph	300	225	195	225	296	509	460	676	777	20	570x750x1050	34

MEAT GRINDER

- Made from diecast polished aluminium.
- Ventilated motor.
- Oil-bath gear box
- Cast iron head and feeding worm (AISI 304 stainless steel on demand).
- S/S plates and knives.
- CE version: 24 volt controls and NVR device.
- Optional: Reverse.

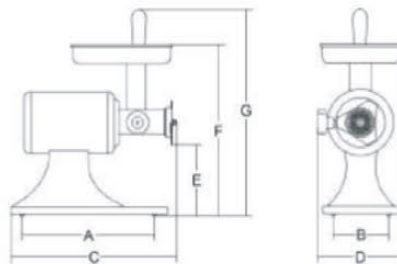

- Anodized aluminium body and ABS shockproof sides.
- Ventilated motor.
- Oil-bath gear box.
- Ground tempered helical gears.
- Bright finished mouth and feeding worm.
- S/S plates and knives.
- Compartment for knives and plates.
- Reverse (optional).
- CE version with: IP 54 protection rated controls and NVR device.

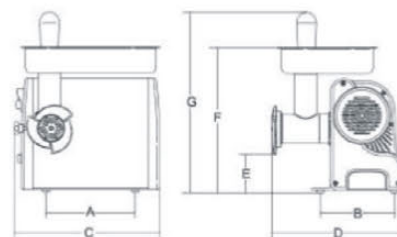

	power	power Source	out/put/n	standard plate	(A)	(B)	(C)	(D)	(E)	(F)	(G)	net weight	shipping	gross weight
	watt/Hp		KG/10MIN	Ømm	mm	mm	mm	mm	mm	mm	mm	kg	mm	kg
TC 12E	735/1	230-400V/50HZ	25	4.5	225	185	430	215	140	445	520	18	320X460X470	20
TC 22E	800/1.2	230-400V/50HZ	33	4.5	225	185	440	215	135	445	520	21	320X460X470	23
TC 8 VEGAS	250/0.34	230V/50HZ	70	6	205	170	335	300	85	360	410	10	560X400X350	12

MEAT SLICER

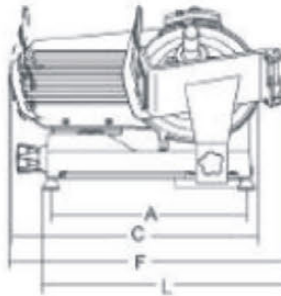

- Anodized cast aluminium alloy.
- Great distance between blade and motor
- for easy cleaning.
- Ventilated motor.
- Forged, hardened large thickness blades.
- Carriage running on self-lubricating bushes and lapped pins.
- Stainless steel screws and slice deflector.
- Strong thickness gauge support.
- Cast-in sharpener assembly.
- Compact dimensions and great cutting capacity.
- CE professional with device for releasing the carriage.
- Teflon coated or toothed blades are available on demand.
- 25° blade inclination.

	Øblade	motor	cut thickness	run of carriage	hopper	(A)	(B)	(C)	(D)	(E)	(F)	(G)	(L)	(X)	(Y)	(H)	(W)	net weight	shipping	gross weight
	mm/inch	walt/Hp	KG/10MIN	Ømm	mm	mm	mm	mm	mm	mm	mm	mm	mm	mm	mm	mm	mm	kg	mm	kg
Topaz 195	195/8"	110/0.15	13	162	185X165	310	220	370	355	300	385	360	370	140	110	135	120	10.5	430x400x370	12
Topaz 220	220/9"	145/0.20	13	245	200X220	380	250	440	410	330	550	400	450	200	130	145	140	13	600x500x420	15
Topaz 220 C	250/10"	145/0.20	13	240	230X230	380	250	480	410	360	500	410	475	185	165	180	14	600x500x450	16	
Topaz 275	275/11"	145/0.20	13	235	220X225	412	2555	520	410	370	525	455	505	200	190	205	205	16.5	600x500x500	19
Mirra 300 Y09	300/12"	210/0.29	13	285	250X275													20.5	640x610x510	23.5
Palladio 350	350/14"	390/0.50	23	310	305X270	465	340	660	575	455	710	530	580	270	225	275	250	37	760x640x700	46

BONE SAW

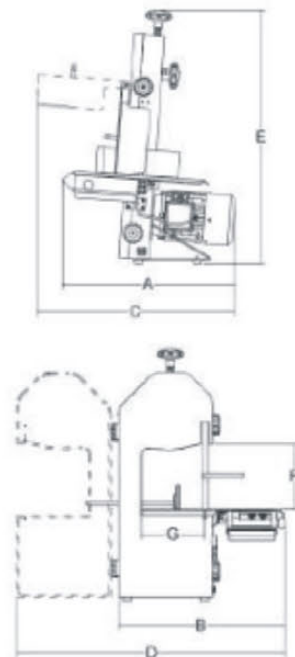

- Simple and sturdy machines that are safe and easy to use.
- Stand-alone structure made out of cast anodized aluminium, shiny, hygienic and rustproof.
- Features a counter, meat pusher and serving slicer in stainless steel AISI 304.
- 24V controls with safety micro-switch on door, redundant ECU and motor brake (EC).
- Ease and precision in both horizontal and vertical adjustment of the upper pulley.
- Maximum blade adhesion to the pulley, thanks to the semi curved shape of the pulleys and ideal adjustment.
- Sealed bearings on upper pulley.
- Smooth cleaning thanks to 2 special manufacturing details:
- All the electrical parts are located beneath the work surface inside an appropriate IP 65 insulated box.
- By simply unscrewing two knobs, you can remove the blade, upper pulley and its support, thereby making for a surface void of any encumbrance.
- Powerful asynchronous and ventilated 4-pole motors protected by sealing oil sump.
- Equipped with 16 mm tempered blades for cutting bones, frozen foods and fresh foods.

	Øblade	motor	cut thickness	run of carriage	(A)	(B)	(C)	(D)	(E)	(F)	(G)	net weight	shipping	gross weight
	mm	Hp/rpm	mm	mm	mm	mm	mm	mm	mm	mm	mm	kg	mm	kg
SO 1550 F3	1550	1ph 1/1400-3ph 1.5/1400	210	400x420	530	510	606	822	778	215	195	32	720x570x1200	44
SO 1650 F3	1650	1ph 1/1400-3ph 1.5/1400	210	430x475	530	600	640	950	915	250	200	39	720x570x1200	51
SO 1840 F3	1840	1ph 1/1400-3ph 1.5/1400	250	430x475	530	600	640	950	915	250	240	40	720x570x1200	52
SO 2020 INOX	2020	900	250	480x600								61	760x640x1430	73

SALAMANDER



BASIC

- Made from stainless steel.
- Heating up controlled by a symostat.
- Galvanized steel gridiron and heating element protection grill.
- Easy to remove crumb pan. Grindiron can be placed on 4 levels accordingly
- to the cooking requirements.

PRO 1/2 - 1/1G

- Stainless steel body.
- High on the heating structure can be adjusted.
- Easy to remove crumb pan.
- Galvanized steel gridiron.
- Shock proof heating elements.
- Vent outlets.
- Electronic symosthats.

	⚡	⚡	⚡	⚡	⚡	A	B	C	D	E	F	G	⚡	⚡	⚡
	walt/Hp	ph	n.	mm	mm	mm	mm	mm	mm	mm	mm	mm	kg	mm	kg
BASIC	2.800	1ph	1	480x330 h.320	-	620	350	445	430	-	-	-	16	670x450x480	18
PRO1/2G	1.700	1ph	1		385x350	330	400	400	545	510	30	240	45	500x630x650	50
PRO1/1G	3.400	1ph	2		585x350	510	400	600	545	510	30	240	56	750x630x630	66

POTATO PEELER

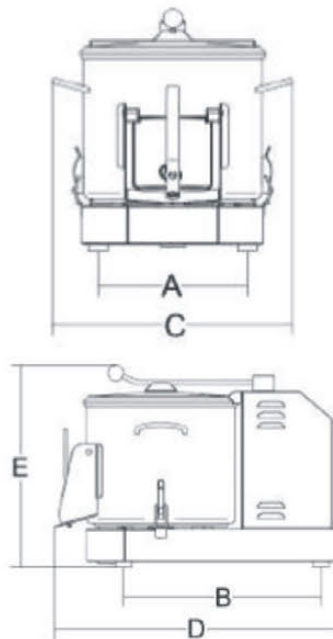

- Made from AISI 304 Stainless steel.
- Poli-V belt drive.
- High efficiency ventilated motors for continuous operation.
- Stainless steel peeling disc.
- Patented removable dishwashing safe container and bottom peeling disc (no tools required) Automatic unloading system.
- Stainless steel outlet opening with quick and sealed locking.
- Drain filter option available.

CE VERSION WITH

- Microswitch on the lid.
- Microswitch on outlet opening.

	⚡	⚡	⚡	A	B	C	D	E	F	G	H	⚡	⚡	⚡
	walt/Hp	ph	KG/10MIN	Ømm	mm	mm	mm	mm	mm	mm	mm	kg	mm	kg
PPJ6 SC	370/0.50	1ph/3ph	320	6/10	105	220	260	400	400	690	-	23	720x570x1020	35
PPJ 6	370/0.50	1ph	320	6/10	105	260	320	400	550	440	-	31	500x630x650	36
PPJ 10 SC	735/1	1ph/3ph	320	10/20	170	203	282	470	544	910	-	41.5	720x570x1200	51.5
PPJ 10	375/1	1ph/3ph	320	10/20	170	203	282	470	775	1050	1310	51	720x570x1200	61
PPJ 20 SC	1.102/1.5	1ph/3ph	275	20/35	340	295	337	560	650	1040	-	52	640x760x1400	62
PPJ 20	1.102/1.5	1ph	275	20/35	340	295	337	560	880	1190	1545	58	640x760x1400	68

SLOW JUICER

EKTOR 37

FROM THE SIRMAN SLOW JUICERS RANGE, WE INTRODUCE THE MODEL EKTOR 37 WITH THE FOLLOWING FEATURES;

Low-speed juicer extractor for fruits and vegetables stainless steel construction.

- special introduction hopper for easy loading of larger pieces.
- High efficiency screw propeller.
Drip cap.
- Quick and easy disassembly of the parts used for processing.
- pestle for easy introduction of the products.
cleaning brush.
- equipped with 2 trays one for juice and one for waste.
- equipped with 3 different drilling strainers.
- high efficiency asynchronous ventilated motor.



	watt/HP	ph	l pm	mm	mm	mm	mm	mm	mm	mm	mm	mm	kg	mm	kg
EKTOR 37	250/0.34	1ph	37	140x80	145	220	240	342	450	530	160	166	6.7	370x290x340	8

JUICE EXTRACTORS

J 80 ULTRA

Induction motor	✓
Power	750 w
Voltage	Single phase
Flow rate	120 L/h
Blow	Stainless Steel
Feed hopper	✓- Automatic Ø 79 mm
Filter	Stainless Steel
Grating disc	Stainless Steel
Useful height under spot	155 mm
Type of service: Glass	✓
Jug	✓
Blender bowl	- 1 Size
No-splash spout	-
Sloping base	✓
Drip catcher tray	✓
Automatic pulp ejection	6.5L
Continuous pulp ejection chute	-



VEG. PREPARATION MACHINE



Blixer® 3



Blixer® 4



Blixer® 5

Induction Motor			
Power	750 w	900 W	1 500 W
Voltage	Single phase	Single phase	Three phase
Speed	3 000 rpm	3 000 rpm	1 500 rpm - 3 000 rpm
Pulse			
Motor Base	Composite material	Metal	Metal
Bowl	3.7 L stainless steel	4.5 L stainless steel	5.9 L stainless steel
Watertight lid			
Blixer arm			
Blade	Stainless steel fine serrated blade with removable cap-	Stainless steel fine serrated blade with removable cap-	Stainless steel fine serrated blade with removable cap-
	Included	Included	Included
Number of 200 g Portions	2-10	2-15	3-20

VEG. PREPARATION MACHINE



CL 50



CL 52



CL 55 2 FEED HEADS

Induction Motor	CL 55 2 Feed Heads	
Power	750 w	1100w
Voltage	Single Phase	Three phase
Speed	375 rpm	375 rpm - 750 rpm
Feed Hoppers	Stainless steel automatic feed tube full moon pusher feed head 4,4 l Cylindrical Hoppers Ø 58 mm and 39 mm, Exactitube Pusher - included	
Lid and bowl	Metal	
Motor base	Stainless Steel	
Mobile Stand	Stainless Steel Equipped With 2 wheels and brake	
Discs	Not included	

Induction Motor	CL 60 2 Feed Heads	
Power	1500w	
Voltage	Three phase	
Speed	375 rpm - 750 rpm	
Feed Hoppers	Stainless Steel Automatic feed tube Full moon pusher feed-head 4.9 L Cylindrical hopper Ø 58 mm and Ø 39 mm, Exactitube pusher - Included	
Lid and bowl	Stainless steel	
Motor base	Stainless steel	
Mobile Stand	1 adjustable foot for all floor types 2 Wheels 1 Stainless steel container for cutting attachments	
Discs	Not included	

Induction Motor	CI50	CI 52
Power	550 W	750 W
Voltage	Single phase	Single phase
Speed	375 rpm	375 rpm
Feed Hoppers	Half moon hopper 2.2 L Cylindrical hopper Ø 58mm and Ø 39 mm, Exactitube pusher - included	full moon hopper 4.4 L Cylindrical hopper Ø 58 mm and Ø 39mm, Exactitube pusher - included
Lid and bowl	Metal	Stainless steel
Motor base	Composite	Not included
Discs	Not included	

IMMERSION BLENDER



- SOUPS**: Images of various soups like tomato, chicken, and vegetable.
- SAUCES**: Images of various sauces like ketchup, pesto, and BBQ sauce.
- COULIS**: Images of coulis like strawberry, raspberry, and cream.
- EMULSIONS**: Images of emulsions like hollandaise, mayonnaise, and dressing.

The emulsifying disc is available on the mini and MicroMIX product lines.

CENTRIFUGAL JUICE EXTRACTOR #50



- Motor-800 W
- Heavy duty, particularly silent.
- Single phase:
 - 220-240V - 50/60Hz
 - 100-120V - 50/60Hz
 - 3000 RPM (50Hz)
 - 3300 RPM (50Hz)
- Thermal Protector
- Weight
 - Net weight : 16 kg (35 lbs)
 - Shipping weight : 17kg (38lbs)
- Dimensions / packed (box)
 - Height : 450 mm (18") /500mm (20")
 - Width: 260 mm (10") /500mm (12")
 - Depth : 470 mm (19") /500mm (21")
 - Shipping cube 0,080m³-2,9 cubic feet
- Removal centrifugal basket made of micro perforated stainless steel sheet
- Standard basket is provided with 0,5 mm diameter holes.
- Continuous juice production by centrifugal action and height of the spout 8" (200mm) allows for use of High glasses of containers.
- High output more than 1 liter / minute.
- Wide circular feeding hole (diameter 79mm;3")no need to cut fruits or vegetables.
- Stainless steel bowl and base.
- Easy to use, easy to clean.
- Patented locking-unlocking system with special lever.
- motor braking when opening.
- Hygiene
- All removable parts can be put in a dishwasher of easily cleaned with hot soapy water (NSF approved).
- STANDARDS
 - Version 50 & 50C (220-240V-50/60Hz): CE, GS,RoHS.
 - Version 50 & 50C (220-240V-50/60Hz): CE, UL, NSF, RoHS

"Classic" Citrus juicer #11

The genuine commercial citrus juicer since 1954 for All citrus fruits: LIMES, LEMONS, ORANGE, GRAPEFRUITS. IDEAL FOR HOTELS, BARS, RESTAURANTS.

Motor asynchronous single phase

220-240V - 50
1500 RPM (50Hz)

Construction

Sanitary aluminum alloy base.
Unbreakable sanitary polycarbonate bowl

Weight

Net wight : 5kg (11lbs)

Dimensions:

H-350 mm x W-200 mm x D-300mm

Easy to clean (NSF approved)

The whole bowl assembly including bowl, pipe, grid and squeezer (cone), is easily taken out from the base in a simple movement.



ICE CRUSHER #09 FOR CRUSHED AND SNOW ICE



SPECIFICATION

Capacity	1 kg/min
Dimension (mm)	420x250x350
Voltage	220V / 50 Hz
Power (W)	600
Speed at 50 Hz (rpm)	1500 tr / min



Compact Brushless Blender # 66

Blender #66 can be used either counter top or in counter, without any additional option (simple and quick dismantling of the base).

SANTOS 66

Equipped with a permanent magnet rotor, the brushless motor has many advantages:

- No maintenance
- Long lifetime
- Low noise level
- Excellent energy efficiency

Speed	Max Torque: 8N.m
Volts	220-240 V-50/60 Hz
Weight	6.2Kg (13.7 lbs)
Dimension (mm)	440x200x247

DECK OVENS / RACK OVENS



QUALITY OF COOKING

The unique system of ceramic resistances, the use of black paneled sheet, the design and construction of the door resistance assemblies among others, make it obtain an incomparable cooking quality



LOW CONSUMPTION.

Designed to consume as little energy as possible. Through the use of high intensity insulation of rock wool, an ECO design of the doors and other components.



LONG USEFUL LIFE.

High quality components and a design oriented to provide a Long service life and low oven maintenance.

MODULE (60X10)	COOKING SURFACE (MM)	INSIDE HEIGHT	Nº TRAYS	DOOR TYPE	STEAM
EM	817X669	200	2 (60X40)	PASTRY / PIZZA	OPTIONAL
EMT	669X817	200	2 (60X40)	PASTRY / PIZZA	OPTIONAL
E	1217X669	200/300	3 (60X40)	PASTRY / PIZZA	OPTIONAL
EMD	1217X869	200	4 (60X40)	PASTRY / PIZZA	OPTIONAL
ED	1217X1269	200/300	6 (60X40)	PASTRY / PIZZA	OPTIONAL

MODULE (75X45)	COOKING SURFACE (MM)	INSIDE HEIGHT	NO TRAYS	DOOR TYPE	STEAM
NXM	952X911	200/300	2 (75X45)	PAST./BAKERY/PIZZA	OPTIONAL
NXE	1410X911	200/300	3 (75X45)	PAST./BAKERY/PIZZA	OPTIONAL
NXD	1410X1678	200	6 (75X45)	PAST./BAKERY/PIZZA	OPTIONAL



SR 21 E+V



SK 22 E+V

THE RANGE

MODEL	SR 21 E+V	SK 22 E+V
POWE (kW)	230/400V	230/400V
WEIGHT	1650	1650
DIMENSION	2022X1791X2197	1275X1957X2197

METRO CONVECTION OVENS



MODELS	KX5-H	KX9+H
EXT. MEASUREMENT	915x1059x535mm	915x1059x535mm
NET CAPACITY	5 trays of 60x40 cm or 66x46cm	5 trays of 60x40 cm or 66x46cm
SPACE BETWEEN TRAYS	80 mm	103 mm
POWER	7.5kw (3+N+T) 3ph	14.5kw (3+N+T) 3ph
WEIGHT	120 kg	195 kg

SPIRAL MIXERS



GENERAL DIMENSIONS



	A	INSIDE B	C	D	E	E	WEIGHT
AE-25	745 MM	675 MM	720 MM	1260 MM	1290 MM	1290 MM	260 kg
AE-50	745 MM	845 MM	1250 MM	1425 MM	1850 MM	1850 MM	450 kg

AMOUNT OF FLOUR 25 KG (60% HYDRATION)

KW	V	A	Hz
1.5/3 III+N+T	400	5.3 8.5	50

Amount of flour 50 kg (60% hydration)

KW	V	A	Hz
4.2 / 6.5 III+N+T	230	20.4 28.7	50
	400	13.7 15	

PLANETARY MIXERS



SP-502A



SP-800A (WITH TIMER)
SP800B (WITHOUT TIMER)



SP-200A



SP-25MA



SP-30HA



SP-30/34HA



SP-40/50/60HA



SP-40/50/60HA

SPECIFICATION

MODELS	CAPACITY	MOTOR POWER	VOLTAGE 60HZ/50HZ	WEIGHT (N.W)	PACKAGE LXWXH MM	AGITATOR R.P.M.	REDUCTION ACCESSORIES	MINCER ATTACHMENT	VEGET ATTACHMENT
SP- 502A	5 LITER	750W	100V/220V	15 KGS	470X370X520	70-490			
SP- 800A	8 LITER	1/3 HP	110V/220V	25 KGS	500X350X650	132/224/412			
SP- 800B	8 LITER	1/3 HP	110V/220V	25 KGS	500X350X650	132/224/412			
SP- 200A	20 LITER	1/4 HP	110V/220V	92 KGS	600X560X1070	105/195/354	10 LITER	VH-12	V99S
SP- 25MA	24 LITER	3/4 HP	110V/220V	92 KGS	630X560X1060	98/177/341	10 QT	VH-12	V99S
SP-30HA	30 LITER	1.0 HP	220V/380V	195 KGS	730X670X1370	93/165/319	20 LITER	VH-12	V99S
SP- 34MA	40 LITER	1.25 HP	220V/380V	185 KGS	730X670X1270	93/165/319	20 QT	VH-12	V99S
SP- 40HA	40 LITER	1.5 HP	22V/380V	260 KGS	820X700X1500	90/161/291	20 LITER	VH-12	V99S
SP- 60HA	60 LITER	3 HP	220V/380V	285 KGS	850X710X1500	83/149/267	30 & 40 LITER	VH-12	V99S
SP- B80HI	80 LITER	3 HP	220V/380V/415V 50/60HA 3PH	400 KGS	1220X800X1770	62/108/182/320	40 & 60 LITER	VH-12	V99S

CONVECTION OVENS



XF003



XF023



XF043



XFT-133



MODELS	CAPACITY	PITCH	POWER SOURCE	ELECTRICAL POWER	DIMENSIONS WXDXH	WEIGHT
XF003	3 342X242	70 MM	230V~1N	2.7 kW	480X402X523 MM	16 KG
XF023	4 460X330	70 MM	230V~1N	3.0 kW	600X472X587 MM	22 KG
XF043	4 600X400	70 MM	230V~1N/400V~3N	5.3/3.2 kW	800X472X706 MM	44 KG
XFT-133	4 4600X330	75 MM	230V~1N	3.0 kW	600X651X509 MM	31 KG



XEFT-04HS-ELDV



XEFT-04EU-ELDV



XEFT-04EU-ETRV



XEFT-06EU-ELRV

MODELS	XEFT-04HS-ELDV	XEFT-04EU-ELDV	XEFT-04EU-ETRV
COMMERCIAL NAME	ARIANNA	ROSSELLA	ROSSELLA. MATIC
POWER SUPPLY	ELECTIC	ELECTIC	ELECTIC
TYPE OF CONTROL	LED	LED	TOUCH
NUMBER OF TRAYS	4 TRAYS	4 TRAYS	4 TRAYS
TRAY SIZE	460X330	600X400	600X400
PITCH	75 MM	75 MM	75 MM
FREQUENCY	50/60Hz	50/60Hz	50/60Hz
VOLTAGE	23V 1N~	400V 3N~	400V 3N~
WEIGHT	39 KG	57 KG	57 KG
ELECTRIC POWER	3.5 Kw	36.9 Kw	6.9 Kw
NOMINAL GAS POWER MAX.	—	—	—
WIDTH	600 M	800 M	800 M
DEPTH	669 MM	811 MM	811 MM
HEIGHT	500 MM	500 MM	502 MM

FOOD SERVICE TROLLEY



1000-MR2-1

MOBILE REFRIGERATED CARD 1000-MR2-1

- Mobile fridge unit
- Full perimeter bumper, flush transport handles, heavy duty casters along with cart's reduced height provide easy mobility
- Capacity : 24xgn 1/1 (65mm deep) // 12xgn 2/1 (65mm deep)
- Maximum weight : 131 kg
- Maximum volume : 228 Liters
- Voltage : 230v / 1ph/0.43kw
- Cart is factory preset to operate between -2° C and +4°C



1200-UP

MOBILE HOLDING CABINET

- Alto-Shaam HALO HEAT™ heating technology
- Holding temperature range 16°C To 96°C
- Voltage :230v /1ph /1.8kw
- Very low energy consumption-
- Product moisture is retained without adding water.
- will hold the food at the required temperature for 2 to 4 hours
- 16xgn 1/1 or 08x gn 2/1 (65mm deep)**per compartment
- max. weight : 87 kg;Max. volume :152 liters **per compartment



300-HWI/D6 400-HWI/D6

HOT FOOD HOLDING DROP-IN WELL



- Alto-Shaam HALO HEAT™ heating technology (dry heat)
- Waterless units (major saving & eco-friendly).
- no plumbing needed. no hygiene issue
- Holding temperature range : 15°C to 96°C
- 300-HWI/D6 voltage :230v/1ph/1.2kw
- 400-HWI/D6 voltage :230v/1ph/2.4kw
- Very low energy consumption
- 300-HWI/D6 capacity : 3X GN 1/1 (150mm deep max)
- 400-HWI/D6 capacity : 4X GN 1/1 (150mm deep max)

500-2D

DRAWER WARMERS



- A2-level unit
- Alto-Shaam HALO HEAT™ heating technology (dry heat)
- Holding temperature range : 15°C to 96°C
- Voltage : 230v/1/0.55kw
- very low energy consumption
- Capacity :2xGN1/1 (150mm deep max)
- Comes With 2GN insert (150mm deep)

BAR BLENDER



DRINK MACHINE 2 SPEED
1.4 LTR JAR|2.0 HP MOTOR



DRINK MACHINE ADVANCE
0.9 LTR JAR|2 HP MOTOR



TOUCH & GO
0.9 LTR JAR | 2 HP MOTOR



THE QUIET ONE
0.9 LTR JAR|3 HP MOTOR



BAR BLENDER



HBB-255CE
1.4 LTR JAR
1.6HP MOTOR



HBH-550CE
3 HP MOTOR | 1.8 LTR JAR
WITH TIMER



HBH-650
3 HP MOTOR | 1.8 LTR JAR
2 SPEED WITH TIMER



HBH-850
1.8 LTR JAR | 3 HP MOTOR
TOUCHPAD WITH SOUND
ENCLOSURE

BAR BLENDER



TM-767A
1.5 LTR JAR | 3 HP MOTOR



TM-800A
1.5 LTR JAR | 3 HP MOTOR
WITH TIMER



TM-800AQ
1.5 LTR JAR | 3 HP MOTOR
WITH TIMER | SOUND ENCLOSURE



TM-767AQ
1.5 LTR JAR | 3 HP MOTOR
WITH SOUND ENCLOSURE

BAR BLENDER



2.2T
2.5 LTR JAR | 2.2 HP MOTOR
WITH TIMER



2.2AQT
2.5 LTR JAR | 2.2 HP MOTOR
WITH TIMER | SOUND ENCLOSURE

DECORATIVE LAMP CONFIGURATION

Hatco's Decorative Lamps provide the two-fold benefits of brief foodwarming and attractive presentation, while decorative, luminaries solely provide lighting to better illuminate your food display areas.



Glo-Ray® aluminum infrared strip heaters



Safety hold the temperature of your product without drying out of further cooking food with hatco's Glo-Ray® infrared aluminum strip heaters the end result is hot, fresh food that's ready-to-serve. the continuous aluminum housing and heavy-duty mounting ensure the durability and quality of hatco products.

STANDARD FEATURES

- Prefocused heat pattern covers the entire holding surface
- Consistent holding temperatures with no "cold spots"
- Sturdy extruded aluminum housings that do not sag, in width from 18" to 144" [457 to 3658mm]
- Standard and high watt models available
- Reflector does not blacken, maintaining a consistent heat pattern
- Protective wire guards under heating element
- Insulation minimizes heat loss
- Factory assembled with mounting tabs, ready to install quickly and easily
- All units single phase only
- Additional reflector styles and lower wattage elements also available,

CONVEYOR TOASTER

ALL THE FEATURES OF A HIGH-END TOASTER... WITH A LOW-END PRICE

The HATCO toast-max economy conveyor toaster offers the flexibility and performance to perfectly toast bread and buns fast up to 300 slices per hour! utilizing conveyor speed, not temperature, to determine toasting color, allows for instant adjustment of toasting time.

- 4- position toast selector switch off/toast / buns / stand-by mode
- 89 mm (3 1/2") clearance to accommodate high profile bread products
- easy-to load rack with front or rear discharging
- Permanently lubricated 50/60Hz motor
- V-shaped reflectors help capture and redirect heat
- Long Lasting serpentine metal sheathed heating elements
- 102mm (4") adjustable legs
- Pilot light that signals unit is in operation
- discharge and crumb trays are removable for easy cleaning



Toasting capacity may vary by product. toasting of coated products is not recommended.

MODELS	kW	Type	Cap./Min.	shipping Weight
TM-5H	1.3	Bread & Buns	3 slices	16 kg (36 lbs.)
TM-10H	1.9	Bread & Buns	6 slices	19 kg (41 lbs.)

SELECTOR CHART

[Based on serving 2 slices per customer]

NUMBER OF CUSTOMERS	SERVING TIME TM-5H	SERVING TIME TM-10H
30	24 MINUTES	12 MINUTES
60	48 MINUTES	24 MINUTES
90	72 MINUTES	36 MINUTES
120	96 MINUTES	48 MINUTES

ELECTRIC RATING

MODELS	VOLTS	WATTS	AMPS	Hz
TM-5H	220-240	1340-1595	6.1-6.6	50-60
TM-10H	220-240	1940-2300	8.8-9.6	50-60

DIMENSIONS

TM-5H : 290 W X 419 D X 387 HMM
 TM-10H : 368 W X 419 D X 387 HMM

INTERIOR CAVITY OPENINGS

TM-5H : 187 W X 88 MM H
 TM-10H : 264 W X 88 MM H

MAXIMUM PRODUCT SIZE

245 W X 64 MM H

CORD LOCATION

LEFT SIDE OF BACK OF UNIT NEAR CENTER.

COMMERCIAL MICROWAVE

MODEL	RMS 510TS
Control system	Touch
Programmable Control Pads	10
Settings Programmable	20
Max. cooking time (min.)	60:00
Power levels	5
Display	LED
Stage cooking	Yes,3
exterior dimensions (WxDxH) mm	510x420x310
Usable Cavity space	25.5 liters (0.9 cu. ft.)
Exterior finish	Stainless steel
Power consumption (watts)	1150 W, 9.6 A
Power output (watts)	1000 W
Power source (V/Hz/A)	230v/50 Hz/ 15 A/ 1pH
Product weight (Kg.)	14.5 kg. (32 lbs)



PRODUCT DETAILS

- 1000 Watts of power
- Five power levels for cooking flexibility
- Multiple users and variable ambient temperatures.
- 20 Programmable menu items for simplifying cooking.



KEY FEATURES

- 25 litre capacity accommodates 12" platter
- Up to 20 programmable menu options for consistent results
- User friendly touch control pad
- 3 stage cooking and 5 microwave power levels
- See-through door with lighted interior
- Grab'n Go handle
- Stainless steel cabinet and oven cavity
- Removable splatter shield

TECHNICAL DESCRIPTION

- Cavity Volume (Litres) – 25
- Input Power (W) – 1550
- Output Power (W) – 1000
- Cooking Time (min:sec) – 3:10



UPRIGHT CHILLER / FREEZER RANGE



UPRIGHT CHILLER RANGE

MODELS	GROSS VOLUME (LTR)	NET WEIGHT	EXTRENAL DIMENSIONS WxDxH(MM)	INTERNAL DIMENSIONS WxDxH(MM)	TEMPERATURE RANGE	SHELF	REFRIGERANT	POWER SUPPLY	HEAT REJECTION	TEMPERATURE CONTROL	COMPRESSOR CAPACITY
HRW-77MS4	628	116 KG	700X818X2050	596X700X1505	-2°C TO 12°C	4	R134a/245gram	230V AC/50Hz	0.641 KW	ELECTRONIC	429 W
HRW-127MS4	1119	168 KG	1200X818X2050	1076X690X1495	-2°C TO 12°C	8	R134a/370gram	230V AC/50Hz	1.452 KW	ELECTRONIC	
HRW-147MS4	1365	181 KG	1400X818X2050	1296X700X1505	-2°C TO 12°C	8	R134a/370gram	230V AC/50Hz	1.452 KW	ELECTRONIC	

UPRIGHT FREEZER RANGE

HFW-77MS4-IC	628	122 KG	700X818X2050	596X700X1505	-7°C TO 25°C	4	R134a/245gram	230V AC/50Hz	1.328 KW	ELECTRONIC	-----
HFW-127MS4-IC	1109	178 KG	1200X818X2050	1076X690X1495	-7°C TO 25°C	8	R134a/370gram	230V AC/50Hz	2.372 KW	ELECTRONIC	
HFW-127MS4-IC	1365	189 KG	1400X818X2050	1296X700X1505	-7°C TO 28°C	8	R134a/370gram	230V AC/50Hz	2.372 KW	ELECTRONIC	

UNDERCOUNTER CHILLER RANGE

RTW-70MS4	172	64 KG	700 X 750 X 850	580 X 620 X 588	-2°C TO 12°C	2	R134a/155 gram	230V AC/50Hz	0.472 KW	ELECTRONIC	
RTW-120MS4	306	100 KG	1200 X 750 X 850	832 X 360 X 588	-2°C TO 12°C	4	R134a/180gram	230V AC/50Hz	0.586 KW	ELECTRONIC	
RTW-150MS4	418	114 KG	1500 X 750 X 850	1132 X 630 X 588	-2°C TO 12°C	4	R134a/165gram	230V AC/50Hz	0.761 KW	ELECTRONIC	
RTW-180MS4	526	125 KG	1800 X 750 X 850	1432 X 630 X 588	-2°C TO 12°C	6	R134a/165gram	230V AC/50Hz	0.761 KW	ELECTRONIC	
RTW-126MS4	233	89 KG	1200 X 600 X 850	832 X 480 X 588	-2°C TO 12°C	4	R134a/180gram	230V AC/50Hz	0.856 KW	ELECTRONIC	
RTW-156MS4	318	104 KG	1500 X 600 X 850	1132 X 480 X 588	-2°C TO 12°C	4	R134a/180gram	230V AC/50Hz	0.586 KW	ELECTRONIC	
RTW-186MS4	400	113 KG	1800 X 600 X 850	1432 X 480 X 588	-2°C TO 12°C	6	R134a/165gram	230V AC/50Hz	0.761 KW	ELECTRONIC	
RTW-127MS4-GN	282	104 KG	1200 X 700 X 850	832 X 580 X 588	-2°C TO 12°C	4 RAIL	R134a/180gram	230V AC/50Hz	0.586 KW	ELECTRONIC	
RTW-177MS4-GN	436	115 KG	1660 X 700 X 850	1432 X 480 X 588	-2°C TO 12°C	6 RAIL	R134a/165gram	230V AC/50Hz	0.761 KW	ELECTRONIC	



UNDERCOUNTERS

UNDERCOUNTER FREEZER RANGE

MODELS	GROSS VOLUME (LTR)	NET WEIGHT	EXTRENAL DIMENSIONS WxDxH(MM)	INTERNAL DIMENSIONS WxDxH(MM)	TEMPERATURE RANGE	SHELF	REFRIGERANT	POWER SUPPLY	HEAT REJECTION	TEMPERATURE CONTROL	COMPRESSOR CAPACITY
FTW-70MS4	171	68 KG	700 X 750 X 850	580 X 620 X 588	-7°C TO 23°C	2	R134a/165gram	230V AC/50Hz	0.57 KW	ELECTRONIC	----
FTW-120MS4	306	100 KG	1200 X 750 X 850	832 X 630 X 588	-7°C TO 23°C	4	R134a/170gram	230V AC/50Hz	1.328 KW	ELECTRONIC	
FTW-150150MS4	415	114 KG	1500 X 750 X 850	1132 X 630 X 588	-7°C TO 23°C	4	R134a/170gram	230V AC/50Hz	1.328 KW	ELECTRONIC	
FTW-180MS4	525	131 KG	1800 X 750 X 850	1432 X 630 X 588	-7°C TO 23°C	6	R134a/170gram	230V AC/50Hz	1.328 KW	ELECTRONIC	
FTW126MS4	233	89 KG	1200 X 750 X 850	832 x 480 x 588	-7°C TO 23°C	4	R134a/170gram	230V AC/50Hz	1.328 KW	ELECTRONIC	
FTW-156MS4	315	104 KG	1500 X 600 X 850	1132 x 480 x 588	-7°C TO 23°C	4	R134a/170gram	230V AC/50Hz	1.328 KW	ELECTRONIC	
FTW-186MS4	399	119 KG	1800 X 600 X 850	1432 x 480 x 588	-7°C TO 23°C	6	R134a/170gram	230V AC/50Hz	1.328 KW	ELECTRONIC	
FTW-177MS4/LS-GN	436	117 KG	1600 X 700 X 850	1432 x 480 x 588	-7°C TO 23°C	6 rail	R134a/170gram	230V AC/50Hz	1.328 KW	ELECTRONIC	
FTW-127MS4/LS-GN	281	104 KG	1200 X 700 X 850	832 x 580 x 588	-7°C TO 23°C	6 rail	R134a/170gram	230V AC/50Hz	1.328 KW	ELECTRONIC	

BACKBARS



TECHNICAL SPECIFICATIONS

MODELS	RBW-95	RBW-135
DIMENSIONS (MM)	900 (W) X 545 (D) X 900 (H)	1350 (W) X 545 (D) X 900 (H)
GROSS VOLUME (LITRE)	226	349
RATED VOLTAGE (V AC)	230	230
RATED FREQUENCY (Hz)	50Hz	50Hz
NET WEIGHT (KG)	73	94
REFRIGERANT NUMBER MASS (G)	R134a 125	R134a 155
RATED WATTAGE (W)	343	343
TEMP. RANGE @	0 TO 10 C	0 TO 10 C
BOTTLE LOADING (PINT BOTTLES)	153 NOS	236 NOS

KITCHEN REFRIGERATION



CGN 1200 C4/F4, EGN 1410 C4/F4
CGN 1200 CF, RI 1101 C4/F4



CGN 2100 C / EGN 2100 C/F
UC 1501 C / UC 1502 C

REACH-IN & COUNTERS-STATIC & FROST FREE

KEY FEATURES

- **Dixell digital controller**
- Removable gasket
- Adjustable shelves
- Heavy duty lockable

CASTORS

- Lock
- Built in handle
- Environment Friendly

REFRIGERANT

- R134A for Chillers
- R404A for Freezers

OPTIONAL FEATURES

- Left or Right hinged door
- Single or multi door
- Heavy duty adjustable SS

LEGS

- Left or Right side

COMPRESSOR

- Door or drawer options
- Back splash

COMMON - ALL MODELS

- HACCP Compliance
- Adjustable Feet



Choice of Top & Drawers



CGN 600 C2/F2
EGN 650 C2/F2
CGN 600 CF
RI 551 C2/F2

	MODEL	DESCRIPTION	CAPACITY (LTRS)	DIMENSION (WXDXH)MM	TEMPERATURE RANGE	GN COMPATIBILITY	NO. OF SHELVES	CLIMATE CLASS	INSIDE/ OUTSIDE SS
FROST FREE - PREMIUM	EGN 650 C2	2 Door Reach-in Chiller	650	740 x 830 x 2010	-2°C ~ 8°C	2 x GN 1/1	3	43°C	SS 304
	EGN 650 F2	2 Door Reach-in Freezer	650	740 x 830 x 2010	-16°C ~ -22°C	2 x GN 1/1	3	38°C	SS 304
	EGN 1410 C4	4 Door Reach-In Chiller	1410	1480 x 830 x 2010	-2°C ~ 8°C	2 x GN 1/1	6	43°C	SS 304
	EGN 1410 F4	4 Door Reach-in Freezer	1410	1480 x 830 x 2010	-16°C ~ -22°C	2 x GN 1/1	6	38°C	SS 304
	EGN 2100 C	2 Door Under Counter Chiller	265	1360 x 700 x 860	-2°C ~ 8°C	1 x GN 1/1	2	38°C	SS 304
	EGN 3100 C	3 Door Under Counter Chiller	400	1795 x 700 x 860	-2°C ~ 8°C	1 x GN 1/1	3	38°C	SS 304
	EGN 2100 F	2 Door Under Counter Freezer	265	1360 x 700 x 860	-16°C ~ -22°C	1 x GN 1/1	2	38°C	SS 304
FROST FREE - CLASSIC	CGN 600 C2	2 Door Reach-in Chiller	600	680 x 810 x 2000	-2°C ~ 8°C	2 x GN 1/1	3	43°C	SS 430
	CGN 600 F2	2 Door Reach-in Freezer	600	680 x 810 x 2000	-16°C ~ -22°C	2 x GN 1/1	3	38°C	SS 430
	CGN 600 CF	2 Door Reach-in Combi	300C+	680 x 810 x 2000	-2°C ~ 8°C /	2 x GN 1/1	3	38°C	SS 430
			300F		-10°C ~ -20°C				
	CGN 1200 C4	4 Door Reach-In Chiller	1200	1340 x 810 x 2000	-2°C ~ 8°C	2 x GN 1/1	6	43°C	SS 430
	CGN 1200 F4	4 Door Reach-in Freezer	1200	1340 x 810 x 2000	-16°C ~ -22°C	2 x GN 1/1	6	38°C	SS 430
	CGN 2100 C	2 Door Under Counter Chiller	265	1360 x 700 x 860	-2°C ~ 8°C	1 x GN 1/1	2	43°C	SS 430
STATIC - CLASSIC	CGN 3100 C	3 Door Under Counter Chiller	400	1795 x 700 x 860	-2°C ~ 8°C	1 x GN 1/1	3	43°C	SS 430
	RI 551 C	2 Door Reach-in Chiller	550	680 x 710 x 2000	-2°C ~ 8°C	NA	3	43°C	SS 201
	RI 1101 C	4 Door Reach-in Chiller	1100	1340 x 710 x 2000	-2°C ~ 8°C	NA	6	43°C	SS 201
	RI 551 F	2 Door Reach-in Freezer	550	680 x 710 x 2000	-10°C ~ -20°C	NA	3	43°C	SS 201
	RI 1101 F	4 Door Reach-in Freezer	1100	1340 x 710 x 2000	-10°C ~ -20°C	NA	6	43°C	SS 201
	CGN 1200 CF	4 Door Reach-in Combi	600C+	1340 x 810 x 2000	-2°C ~ 8°C /	NA	6	38°C	SS 430
			600F		-10°C ~ -20°C				
	UC 1501 C	2 Door Undercounter Chiller	265	1360 x 600 x 850	-2°C ~ 8°C	NA	2	38°C	SS 201
	UC 1502 C	2 Door Undercounter Chiller	265	1360 x 700 x 850	-2°C ~ 8°C	NA	2	38°C	SS 201
UC 1801 C	3 Door Undercounter Chiller	400	1795 x 600 x 850	-2°C ~ 8°C	NA	3	38°C	SS 201	
UC 1802 C	3 Door Undercounter Chiller	400	1795 x 700 x 850	-2°C ~ 8°C	NA	3	38°C	SS 201	

ICE MACHINE



EIM 101



EIM 201 EIM 351 /EIM 501



EFM 101 (FLAKES)



EIM 1001

MODELS	EFM 101	EIM 35	EIM 41 BW*	EIM 61 BW*	EIM 101	EIM 201	EIM 351	EIM 501	EIM 1001
COMPATIBLE BIN MODEL	INBUILT	INBUILT	INBUILT	INBUILT	INBUILT	B 275	B 375	B 375	B 775
RATED CAPACITY* (Kg/24hrs)	100	30	36	55	95	191	318	455	909
NIN SIZE(KG)	20	10	15	18	40	125	170	170	350
MACHINE DIM. (WxDxH) MM	520x550x960	460x4430x800	500x450x800	500x590x850	660x685x920	560x830x1718	760x830x1718	760x830x1893	1227x973x2048
POWER CONSUMPTION/24HRS	330 W	270 W	270 W	360 W	580 W	1100 W	1420 W	2300 W	3800 W
WATER CONSUMPTION/24HRS	110 L	50 L	40 L	80 L	150L	286 L	477 L	682 L	1363 L
CUBE SIZE (WxDxH) MM	NA	22X22X22	22X22X22	22X22X22	22X22X22	22X22X22	22X22X22	22X22X22	22X22X22

ICE CUBE MACHINE

DICE ICE CUBE MACHINE



MODEL	SQ-40	SQ-65	SQ-120	SQ-275	SQ-550	SQ-1100
CAPACITY (KG/DAY)	18	30	55	125	250	500



ICE CRUSHER MACHINE C-103 | 2KG/MIN

BULLET ICE CUBE MACHINE



MODEL	BVS-60	BVM-130	BVM-210	BUZ-330	BUZ-550	BUZ-900
CAPACITY (KG/DAY)	27	60	95	150	250	400

COLD BEVERAGE DISPENSER



ARCTIC COMPACT 8/1



ARCTIC COMPACT 8/2



ARCTIC COMPACT 8/3

*AVAILABLE IN 5 OR 8 LITER BEVERAGE STORAGE OPTION WITH 1 TO 3 BOWLS



ARCTIC DELUXE 12/1



ARCTIC DELUXE 12/2



ARCTIC DELUXE 12/3

*Available in 12 or 20 liter beverage storage option with 1 to 3 bowls



COLD BEVERAGE DISPENSER



JJ 12
12 Liter



Jolly-8.2
8 Liter

DISHWASHER MACHINE

HOOD TYPE DISHWASHER | PRO TECH 813



TECHNICAL SPECIFICATIONS	
Dimension (cm) w x d x h	64 x 74 x 151
Rack size (cm)	50 x 50
Door opening (cm)	40
Max glass	38
General construction	Single wall
Door construction	Single wall
Water consumption (Ltr/Cycle)	2.2
Electrical connection (V/Hz/ph/N)	400/50/3/N
Cycles (secs)	3(60,120,150)
Output (raks/hour) 50 C water temp	50
Required electrical power (kW/amp)	8.5/16
Required Water pressure (Bar)	2-4
Gross weight (kg)	100

RACK CONVEYOR DISHWASHER | RC 150 PLUS



RACK CONVEYOR DISHWASHER | RC 154 PLUS



UNDERCOUNTER DISHWASHER | PRO TECH 611



UNDERCOUNTER GLASSWASHER | PRO TECH 411



DISHWASHER MACHINE



U50 UNDER COUNTER DISHWASHERS



P50 RACK PASSTHROUGH DISHWASHERS



C50 RACK CONVEYOR DISHWASHER

P50 ELECTRICAL SPECIFICATIONS

SUPPLY	FUSE	TANK	BOILER	TOTAL CONNECTED LOAD
380 V FI 415V, 3N~, 50Hz / 60 HZ	16 A 20 A	2.5 kW 2.5 kW	9.0 kW 9.0 kW	9.3 kW 11.8 kW

U50 ELECTRICAL SPECIFICATIONS

SUPPLY	FUSE	TANK	BOILER	TOTAL CONNECTED LOAD
380 V FI 415V, 3N~, 50Hz / 60 HZ	16 A	2.0 kW	5.3 kW	7.8 kW
220 V FI 240V, 1N~, 50Hz / 60 HZ	16 A 20 A	2.0 kW 2.0 kW	2.6 kW 3.6 kW	3.1 kW 4.1 kW
220 V FI 240V, 3~, 50Hz / 60 HZ	25 A	2.0 kW	5.3 kW	7.8 kW

- DEPENDING ON THE LOCAL CONDITIONS (WATER INLET TEMPERATURE / ELECTRICAL SUPPLY) THE INDICATED DATA CAN DECREASE.
- NON-BINDING INFORMATION. THE ACTUAL NEED FOR RINSE WATER CAN VARY DEPENDING ON THE ON-SITE CONDITIONS
- DEPENDING ON THE LOCAL CONDITIONS (WATER INLET TEMPERATURE / ELECTRICAL SUPPLY) THE INDICATED DATA CAN DECREASE. BY ADJUSTING PARAMETERS THE THEORETICAL CAPACITY CAN BE INCREASED TO 60 RACKS / H (1-MINUTE-PROGRAMME)
- NON-BINDING INFORMATION. THE ACTUAL NEED FOR RINSE WATER CAN VARY DEPENDING ON THE ON-SITE CONDITIONS.

VEGETABLE WASHER MACHINE

MODEL : V50S



NON TILTING TYPE

FEATURES

- WITH IN-BUILT HEATING KW
- BUBBLE WASH TECHNOLOGY
- HEATING LOAD A KW (OPTIONAL USE)
- RUNNING LOAD WATTS
- WITH OZONE STERILIZATION SYSTEM

OZONE IS THE MOST POWERFUL. OXIDATIVE AGENT THE OCCURS NATURALLY, OZONE DESTROYS GERM, VIRUSES, AND MICROBES THAT MAY CAUSE SURFACE OR AIR CONTAMINATIONS. REMOVES RESIDUAL PESTICIDES FROM VEGETABLES AND FRUITS

MODEL : V120T



TILTING TYPE

FEATURES

- SWIRL WASH TECHNOLOGY
- RUNNING LOAD 1500 WATTS
- HYDRAULIC TITLING MECHANISM

CLEANING MADE EASY

- IDEAL FOR WASHING FRUIT & VEGETABLE
- MAINTAINS HYGIENE BY GOOD QUALITY OF WASHING AND KEEPING SURROUNDINGS CLEAN
- SAVES WATER, LABOUR, TIME AND PREVENTS DAMAGE TO FRUITS & VEGETABLES



- FULLY AUTOMATIC OPERATION RIGHT FROM START TO END LIKE AUTOMATIC WATER FILLING, HEATING ETC.
- DRY RUN PROTECTION
- DIGITAL TIMER CONTROL
- JOG WHEEL CONTROL WITH +/-, START/PAUSE/STOP FUNCTIONS
- 12 V DC CONTROL CIRCUIT ENSURES OPERATOR SAFETY FROM ELECTRIC SHOCK.

MERRYCHEF CONNEX® 12

THE NEXT GENERATION

STORE ACCESSORIES
ON TOP OF UNIT

14" (35.5CM) WIDE

STATE-OF-THE-ART, EASY TO
USE 7" HIGH DEFINITION
TOUCHSCREEN

24.4" (61.9CM)
HIGH

HIGHLY ROBUST GLASS SURROUND

CONSTANTLY COOL
TO-TOUCH EXTERIOR
WALLS, ELIMINATES
CLEARANCE NEEDED
AROUND THE
EQUIPMENT

12" X 12" (30.5CM X 30.5CM) CAVITY,
WITHIN A 14" (35.5CM) WIDE OVEN

EASY TO CLEAN, STAINLESS STEEL
AVITY WITH ROUNDED
CORNERS AND SMOOTH SURFACES

FITS ON A 600MM COUNTER-TOP

EASY ACCESS FRONT-MOUNTED
AIR FILTER

USB MEMORY STICK FOR MANUAL
MENU AND SOFTWARE MANAGEMENT



THE MOST COMPACT HIGH SPEED OVEN WITH THE FASTEST SPEEDS.

MODELS	CONVECTION	MICROWAVE	IMPINGEMENT	VENTLESS/CATALYTIC CONVERTER	PLUG TYPE
STANDARD POWER UP TO 15X FASTER	2200W	1000W	YES	YES	13/16 AMP
HIGH POWER UP TO 20X FASTER	2200W	2000W	YES	YES	16/32 AMP

16" CHILLED, PRE-BAKED,
THIN CRUST VEGGIE PIZZA

12 SAUSAGE ROLL

FISH FINGERS
AND FRIES

4 MOZZARELLA AND TOMATO PANINIS



BESPOKE RANGE OF
MERRYCHEF ACCESSORIES
FOR VERT OVEN,
DISCOVER THEM ALL AT:



Placing food on liners and trays will help keep
the ovens clear from food and grease,
significantly reducing cleaning time.

MERRYCHEF HIGH SPEED OVENS



EIKON E1S



EIKON E2



EIKON E3



EIKON E4

SPECIFICATION

MODELS	POWER INPUT	POWER OUTPUT			OVERALL SIZE			PLUG TYPE
		MICROWAVE (IEC 705)100%	CONVECTED HEAT	COMBINATION MODE	HEIGHT	WIDTH	DEPTH	
EIKON E1S	2990 W	800 W	2200 W	800 W* +900 W	(23.2") 588 MM	(16.0") 407 MM	(21.2") 538 MM	NET 46.0 KG (102 LBS) GROSS 56.0 KG (124 LBS)
EIKON E2	3120W	1000 W	2200 W	1000 W**+1300 W	24.4" (620 MM)	14.0" (356 MM)	23.4" (595 MM)	NET 113 LBS (51.3KG)
EIKON E3	3000W	7000 W*	3000 W	700 W* +300/1500 W	551 MM (21.7)	598 MM (23.5")	558 MM (22.0")	62.5 KG (138 KG)
EIKON E4	L1 3.55 KW / L2 3.45KW (TWIN PHASE)	1500 W*	3200 W	1500 W* + 3200 W	591 MM (23.2 IN)	584 MM (23.0 IN)	643 MM (25.3 IN)	82.5 KG (182 LBS)

DIGITAL CONTROL CONVEYORISED OVEN

LINCOLN 1155 CONVEYOR PIZZA OVEN

PRODUCT SPECIFICATION	
CAPACITY	220-240
MACHINE BODY MATERIAL	ss
DESIGN TYPE	Customized

PRODUCT DESCRIPTION

With the valuable assistance of skilled team of professionals, we are engaged in offering an extensive range of high-quality Lincoln 1155 Conveyor Pizza Oven.

SPECIFICATIONS

- Dimension (W x D x H): 80" x 60 1/2" x 19 5/8", 203.2cm x 153.7cm x 49.8cm
- Weight: 727.51b, 330 kg
- Power Input Type: Electric
- Primary Power Input 208-230 V x 60 Hz x 3 PH, 208-240 V X 50 Hz X 3 PH, 208-240 V X 60 Hz X 3 PH



MODEL : 1155 CONVEYOR PIZZA OVEN

LINCOLN 2504-1 DIGITAL COUNTERTOP IMPINGER SERIES ELECTRIC CONVEYOR OVEN

Dimension : 1270mm (W) x 797mm (D) x 457mm (H)
 Single deck electric impinger conveyor oven
 Uniform heating/cooking of food
 Digital control and display
 Stackable up to 2 ovens high
 Capacity: 18 x 12", per hour at 6 minutes
 Conveyor adjustable from 30 seconds to 15 minutes
 Temperature range from 32°C - 315°C Air Impingement
 Reversible conveyor direction left/right
 Includes 100mm legs for proper cooling.
 Power: 240V; Single Phase; 50Hz; 25 Amps; 6kW Per Deck
 Warranty: 12 months parts & labour



MODEL : 2504 CONVEYOR PIZZA OVEN



COMBI COOKING OVENS



ELECTRIC SPRITZER

Fast steam Generation using direct water injection

LED LIGHTING

Optimal lighting in the entire cooking chamber.

HYGIENIC HANDLES

Antibacterial coating.

CONNECTIVITY

Network access via wifi and lan for versatile data management.

ADDITIONAL SHELF

6.10 and 10.10 each with one extra shelf.

INTERGREGED COOKBOOK

with 6 different categories and favorites quick touch.

7-INCH TFT HITES GLASS TOUCH DISPLAY

BRILLIANT resolution, intuitive operation.

DOOR SLAM FUNCTION

no manual latching required

FLEXIBLE APPLIANCE FEET

height adjustable by up to 40 mm.

TRIPLE GLASS COOKING CHAMBER DOOR

energy efficient and safe

PRESS & GO

height-adjustable by up to 40 mm.

ENVIRONMENTALLY FRIENDLY CLEANING

fully automatic convo clean cleaning program



CMX ET 6.10 ES



CMX ET 10.10 ES

MODELS	6.10 ES	10.10 ES
DIMENSION (WxDxH)	875 X 797 X 794 MM	875 X 797 X 1066 MM
LOADING CAPACITY (GN)	6+1	10+1
SHELF SPACING	68 MM	68 MM
FREQUENCY	50 / 60 Hz	50 / 60 Hz
VOLTAGE	3N~ 380-415V	3N~380-415V
RATED POWER CONSUMPTION	9.6 - 11.3 kW	17.2-20.4kw
WEIGHT	104 KG	125.5KG

COMBI OVENS ACCESSORIES

COMBI FRY BASKET (S.S)

(NON-TEFLON COTED)

AVAILABLE SIZE	
GN DIMENSION	SIZE IN MM
1/1 GN	325X530
1/2 GN	325X265



- STAINLESS STEEL MAKE
- OPTIMAL BROWNING AND CRISPNESS

WHOLE CHICKEN ROAST (S.S)

AVAILABLE SIZE	
GN DIMENSION	CAPACITY
1/1 GN	8 CHICKENS
1/2 GN	4 CHICKENS



- EASY TO USE
- JUICE BREAST MEAT
- EXCEPTIONAL WHOLE CHICKEN
- SHORT COOKING TIMES
- LARGE QUANTITIES

BAKING TRAY

(TEFLON COTED)

AVAILABLE SIZE	
GN DIMENSION	SIZE IN MM
1/1 GN	325X530
1/2 GN	325X265



- IN ALUMINUM
- OPTIMAL NON STICK PROPHESES
- BEST FOR SIL PAD

POTATO BAKER (S.S.)

AVAILABLE SIZE	
GN DIMENSION	CAPACITY
SET 1/1GN	325X530
SET 1/2 GN	325X265
SKEWER 5MM	530MM LONG
SKEWER 8MM	530MM LONG



- UP TO 50% QUICKER
- LARGE QUANTITIES TO TOP QUALITY
- EASY TO HANDLE
- EASY TO CLEAN

BAKING TRAY PERFORATED

(TEFLON COTED)

AVAILABLE SIZE	
GN DIMENSION	SIZE IN MM
1/1 GN	325X530
1/2 GN	325X265



- IN ALUMINUM
- OPTIMAL NON STICK PROPHESES
- EASY TO CLEAN

CRISS CROSS GRILL TRAY

(TEFLON COTED)

AVAILABLE SIZE	
GN DIMENSION	SIZE IN MM
1/1 GN	325X530
2/3 GN	325X354



GN PAN SOLID (S.S.)

AVAILABLE SIZE		
GN	CAPACITY	DEPTH IN MM
1/1	325X530	20,40,65,100,150
1/2	325X265	20,40,65,100,150
1/3	325X176	20,40,65,100,150



IDLY TRAY

AVAILABLE SIZE		
GN	CAPACITY	DEPTH IN MM
1/1 GN	325X530	15 IDLY
1/1 GN	325X256	09 IDLY



COMMERCIAL FRYER

SUPER RUNNER FRYERS (GAS AND ELECTRIC)

Outpace the competition in performance and value

MODELS	SR 42G	SR 14E
Oil Capacity	21 Ltr.	20 Ltr
Power	105,000 Btu/hr. [26,481 kcal] [30.8 kw]	14.00 N/A- Electric
Frying Area	4' x 13-3/4" x 4-1/5"	13-3/4" x 13-3/4" x 5-1/4"
No. of Frying Baskets (Dim.)	Two Twin	Two twin
Power Switch & Indicator Light	Yes	Yes
Steel Legs Dimensions	151/2" x 291/4" x 45"	153/4" x 271/4" x 44"



FPPH455 NATURAL GAS 200 LB. 4 UNIT HIGH- EFFICIENCY GAS FLOOR FRYER SYSTEM WITH DIGITAL CONTROLS



FPPH455	
WIDTH	62 5/8 INCHES
DEPTH	29 5/8 INCHES
HEIGHT	45 5/8 INCHES
FRY POT WIDTH	14 INCHES
FRY POT DEPTH	15 INCHES
VOLTAGE	120 VOLTS
BURNER STYLE	OPEN POT
CABINET	STAINLESS STEEL
CAPACITY	200 LB.
CAPACITY PER FRY POT	50 LB.
ENERGY STAR QUALIFIED	YES
GAS INLET SIZE	1 INCHES
NO. OF FRY BASKETS	8
NO. OF FRY POTS	4
PLUG TYPE	NEMA 5-15P
POWER TYPE	NATURAL GAS
SPLIT POT	WITHOUT SPLIT POT
TYPE	GAS FLOOR FRYERS



FPPE 214 CM		FPPE114	
WIDTH	31 3/8 Inches	15 5/8 Inches	
DEPTH	31 Inches	31 Inches	
HEIGHT	45 3/8 Inches	45 3/8 Inches	
PHASE	1 Phase	1 Phase	
VOLTAGE	208 Volts	208 Volts	
WATTAGE	28 Kilowa	14 Kilowa	
BURNER SYLE	Open Pot	Open Pot	
CABINET	Ename	Enamel	
CAPACITY	100 lb.	50 lb.	
CAPACITY PER FRY POT	50 lb.	50 lb.	
ENERGY STAR QUALIFIED	YES	Yes	
NO. OF CONNECTION	3	2	
NO. OF FRY BASKETS	4	2	
NO. OF FRY POTS	2	1	
PLUG TYPE	HARD WIRE	Hardwire	
POWER TYPE	ELECTRIC	Electric	
SPLIT POT	WITHOUT SPLIT POT	Without Split Pot	
TYPE	ELECTRIC FLOOR FRYERS	Electric Floor Fryers	

STONE BASE PIZZA OVEN



MODELS	OUTER SIZE (mm)	STONE SIZE (mm)	POWER	Temp. range
EPO-1D	560 x 570 x 280	410 x 410 - 1 stone	2 kw / 240 v / 50 hz	0-350°C
EPO-2D	560 x 570 x 440	410 x 410 - 2 Stone	3 kw / 240 v / 50 hz	0-350°C
EPO-36	925 x 570 x 430	640 x 470 x 15	4.8 kw / 240 v / 50 hz	20-400°C
EPO-36D Digital model	925 x 570 x 430	640 x 470 x 15	4.8 kw / 240 v / 50 hz	20-400°C

*EPO-36 & EPO-36D also available in gas operated.

COFFEE MACHINES



D24
(SINGLE GROUP)



3121A
(SINGLE GROUP)



3201
(DOUBLE GROUP)



IDCG8020
(COFFEE GRINDER)



COFFEE MACHINES

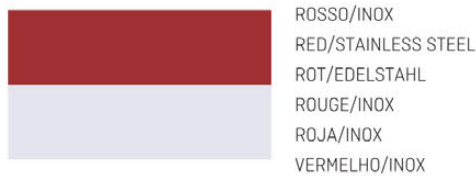

ROSSO/INOX
RED/STAINLESS STEEL
ROT/EDELSTAHL
ROUGE/INOX
ROJA/INOX
VERMELHO/INOX

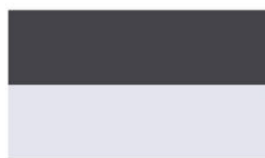

NERO IUCIDO/INOX
GLOSSY BLACK/STAINLESS STEEL
GLANZEND SCHWARZ/EDELSTAHL
NOIR BRILLANT/INOX
NEGRO BRILLANT/INOX
PRETO BRILLANT/INOX

		1 GR.	2 GR.	3 GR.
VOLTAGE	V	120/230-400/240	120/230-400/240	230-400/240
RATED POWER	W	2.200/2.900/3.200	2.800/3.600/3.900	5.300/5.800
BOILER CAPACITY	LT/UK GAL	6/1.3	10,5/2.3	17/3.7
WIDTH	MM/IN	505/19,9	715/28,1	955/37,6
DEPTH	MM/IN	535/20,2	535/21,1	535/21,1
HEIGHT	MM/IN	515/20,2	515/20,2	515/20,2
NET WEIGHT	KG/LB	44/97,00	55/121,25	72/158,73
GROSS WEIGHT	KG/LB	55/121,25	70/121,25	92,202,83

ESPRESSO COFFEE GRINDER

MODEL NO.
A SERIES GRINDER

SPECIFICATION		
DIMENSION	ELECTRICAL	CAPACITY
WIDTH : 210 MM	VOLTAGE: 230 V	HOPPER - 1600G
HEIGHT : 620 MM	FREQ: 50/60 HZ	GRINDING DISC - 64 MM
DEPTH : 360 MM	POWER : 350 W	RPM - 1400RPM
WEIGHT : 13.5 KG		OUTPUT PER HOUR - 4 KG



MANUAL



AUTOMATIC

COFFEE MACHINES - AUTOMATIC



DR. COFFEE - F11
(100 CUPS/DAY)



ROYAL SAECO
(50 CUPS/DAY)



GAGGIA, MAGENTA
(40 CUPS/DAY)

COFFEE MACHINE ACCESSORIES



LEVELER



TAMPER



KNOCK BOX



CLEANING TABLET



TAMPER MAT



MILK PITCHER

linea classic s

CLASSIC RELIABILITY, DESIGN AND VALUE.



The clean lines and charm of the Linea Classic occupies many of the cafes, roasteries, and chains whose names have defined the industry. The Linea Classic has helped to forge the world of coffee over the last 3 decades.

CLASSIC DESIGN

Since its introduction, the Linea Classic has continuously been improved and updated to ensure it continues to deliver unrivaled value. Built to embody the spirit of three words, reserved, reliable, and consistent, the Linea Classic S can be trusted to be a dependable partner in any coffee program. New features provide baristas an easier coffee making experience, while also increasing the reliability of a machine which has already set the standard in the industry. Timers allow baristas to track the brew time of espresso. Dual PID provide consistent temperature in the separate steam and coffee boilers.

TECHNICAL SPECIFICATIONS			
SPECIFICATIONS	1 GRP	2 GRP	3 GRP
HEIGHT (CM/IN)	44,5 / 17,5	44,5 / 17,5	44,5 / 17,5
WIDTH (CM/IN)	49 / 20	69 / 28	93 / 37
DEPTH (CM/IN)	58,5 / 23	58,5 / 23	58,5 / 23
WEIGHT (KG/LBS)	41 / 90	59 / 130	73 / 164
VOLTAGE (VAC)	-	200V SINGLE	200V SINGLE
		PHASE	PHASE
	220V SINGLE	220V	220V
	PHASE	SINGLE / 3	SINGLE / 3
	-	PHASE	PHASE
		380V 3 PHASE	380V 3 PHASE
WATTAGE (MIN)	2500	250	4930
WATTAGE (MAX)	-	-	7790
COFFEE BOILER	1,8	1,8	5
CAPACITY (LITERS)			
STEAM BOILER	3,5	3,5	11
CAPACITY (LITERS)			

linea pb

A HEAVY DUTY WORKHORSE - CAPTURING THE PAST, ENVISIONING THE FUTURE

the Linea PB, designed by and named in recognition of Piero Bambi, introduces a new level of performance, reliability, and craftsmanship.



TECHNICAL SPECIFICATIONS			
SPECIFICATIONS	1 GRP	2 GRP	3 GRP
HEIGHT (CM/IN)	44,5 / 17,5	44,5 / 17,5	44,5 / 17,5
WIDTH (CM/IN)	49 / 20	69 / 28	93 / 37
DEPTH (CM/IN)	58,5 / 23	58,5 / 23	58,5 / 23
WEIGHT (KG/LBS)	41 / 90	59 / 130	73 / 164
VOLTAGE (VAC)	-	200V SINGLE	200V SINGLE
		PHASE	PHASE
	220V SINGLE	220V	220V
	PHASE	SINGLE / 3	SINGLE / 3
	-	PHASE	PHASE
		380V 3 PHASE	380V 3 PHASE
WATTAGE (MIN)	2500	3350	4930
WATTAGE (MAX)	-	5670	7790
COFFEE BOILER	1,8	12M4	5
CAPACITY (LITERS)			
STEAM BOILER	3,5	7	11
CAPACITY (LITERS)			

The Linea PB features the iconic La Marzocco polished stainless steel body, updated with simplified lines and a lower profile, equipped with exclusive, user friendly interface software that gives the barista direct functional control over boiler temperature, brewing volume, hot water tap dose, auto-back flush as well as other options. The Linea PB's lower profile and increased work area also make it practical, without abandoning world renown Italian design.

VERTICAL CONTACT TOASTER | VCT



SPECIFICATIONS

MODEL & MFG. NO.	PASS THROUGH TIME	VOLTS	WATTS	AMPS	HERTZ	PLUG DESCRIPTION
VCT-35	-	208-240	2600-3460	12.5	50/60	CEE7/7 16 AMP., 250 VOLT
VCT-2000	17 SEC.	220-240	3019-3593	13.7-15	50	CEE7/7 16 AMP., 250 VOLT

DIMENSIONS

MODEL & MFG. NO.	WIDTH (A)	DEPTH	HEIGHT
VCT-35	21 1/4" [540 MM]	15 1/4" [387 MM]	23 1/4" [591 MM]
VCT-2000	21 1/4" [540 MM]	15 1/4" [387 MM]	23 1/4" [591 MM]

RAPID STEAMER | RS-1000

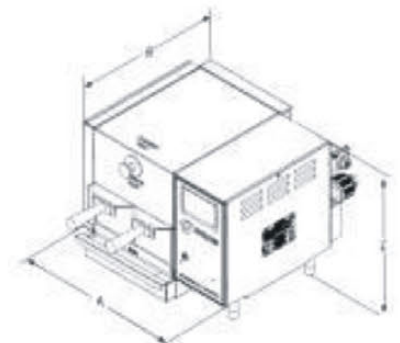

LET STEAMING EXPAND YOUR MENU, COOKING AND REHEATING FOR DISHES OF ALL KINDS.

RS-1000			ELECTRICAL TARGE				DIMENSIONS			
MODEL & MFG. NO.	CAPACITY	PLUG	VOLTS	WATTS	AMPS	HZ.	WIDTH (A)	DEPTH (A)	HEIGHT (A)	SHIPPING WEIGHT
RS-1000 9100651	(2) 17-oz. baskets	IEC-309	200-240	5000	30	50/60	17 1/2" [442 MM]	20 3/8" [517 MM]	12 7/8" [325 MM]	81 LBS (36.7 KG)

DIMENSIONS ARE FOR ITEM WITHOUT SHIPPING BOX. SHIPPING WEIGHT INCLUDES ITEM AND SHIPPING BOX. ITEMS HIGHLIGHTED IN BLUE ARE FOR INTERNATIONAL MARKETS.

COMMERCIAL CATERING ALWAYS EVOLVING

Historically, commercial catering gathers the traditional restaurants with table service and fast food (on-site take-away, home delivery or also nowadays drive-in). commercial catering is the main target of roller grill products.

PIZZA OVEN PZ 430 D

The professional pizza oven PZ 430 D is equipped with an innovative system: a double temperature control. This very compact infrared oven can cook a wide variety of pizzas and dishes in record time.



TECHNICAL DATE	
Inside dimensions	2x (430x430x110 mm)
Power	5 kW or 3 kW (with 2 cords)
Outside dimensions	670 x 580 x500 mm
Weight	55 kg
Volts	380 v ou 230 v mono
Capacity	2 pizzas Ø 41 cm (16")

GAS GYROS GILL

800-MM-HIGH SPIT - 40 KG OF MEAT

The gyros grill kebab grill RG 80 G fits all your dishes of gyros or kebab meat. this vertical gas grill has been designed for easy use and maintenance.



TECHNICAL DATE	
Capacity	40 Kg
Power	14 kW
Dimensions	580 x 660 x 1035 mm
Weight	38 kg
Spindle Height	800 mm

ELECTRIC WAFFLE IRON - GES 20/10

The professional electric waffle iron liege ges 20 is one of the essential waffle makers for classic belgian waffles!



TECHNICAL DATE	MODEL GES 20	TECHNICAL DATE	MODEL GES 20
Waffle side	100 x 180 x 26 mm	Waffle side	00 x 170 x 22 mm
Power	1.6 kw	Power	1.6 kW
Dimensions	305 x 440 x 230 mm	Dimensions	305 x 440 x 230 mm
Weight	22 kg	Weight	22 kg
Volts	230 V	Volts	230 V

CONTACT GRILL

PECIFIC MODEL FOR SANDWICHES

The Cast-iron contact-grill PANINI and SAVOYE is the indispensable professional equipment for intensive use in fast-food restaurants. its specifications are particularly recognized in professional catering.

TECHNICAL DATE	PANINI	TECHNICAL DATE	SAVOYE
Power	2 kW	Cooking surface	260 x 240 mm
Coating	Fonte Brute	Outside dimensions	330 x 385 x 220 mm
Outside Dimensions	430 x 385 x 220 mm	weight	19 kg
Baking surface	360 x 240 mm	volts	230 V
Weight	24 kg	Power	2 kW
Volts	230 V	Coating	Fonte Brute



PANINI

SAVOYE

CAMSHELVING® ELEMENTS® SERIES

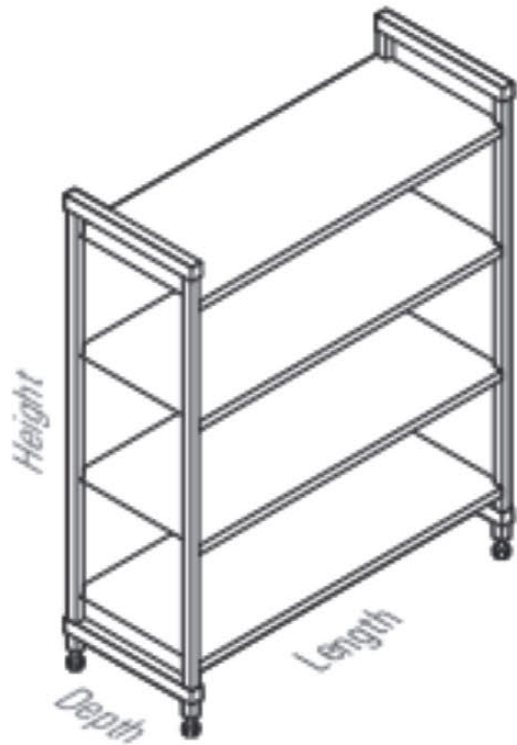

STATIONARY UNIT SIZES	MOBILE UNIT SIZES	UNDERCOUNTER UNIT SIZES
4 DEPTHS	3 DEPTHS	2 DEPTHS
14" 18" 21" 24"	18" 21" 24"	18" 18"
8 LENGTHS	5 LENGTHS	5 LENGTHS
24" 30" 36" 42"	36" 42" 48" 54" 60"	24" 36" 48"
48" 54" 60" 72"		
3 HEIGHTS	2 HEIGHTS	2 HEIGHTS
64" 72" 48"	70 4/1" 78 1/4" [INCLUDES CASTERS]	27 1/4" [MOBILE INCLUDES CASTERS] 30" [STATIONARY]

INSULATED FOOD TROLLEY

UPC 400 | UPC 600 | UPC 800

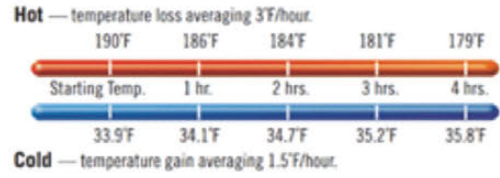

MODEL	EXTERIOR SIZE (MM) W X D X H	INTERIOR SIZE (MM) W X D X H	
UPC 400	450 x 625 x 600	325 x 525 x 475	6 pans
UPC 600	500 x 675 x 1125	275 x 525 x 350	8 pans
UPC 800	500 x 675 x 1350	300 x 525 x 475	12 pans

* Also holds GN 1/2 and 1/3 size pans.

INSULATED BEVERAGE CONTAINER



100 LCD



250 LCD



500 LCD



1000 LCD

MODEL	EXTERIOR SIZE (MM) W X D X H	INTERIOR SIZE (MM) W X D X H	
100 LCD	290 x 265 x 440	6 ltr	27
250 LCD	235 x 432 x 467	9.5 LTR	45
500 LCD	420 x 230 x 620	18 LTR	86
1000 LCD	530 x 415 x 630	44.5 LTR	214



DIM SUM GAS WORK STEAMER WITH BLOWER NGSB 9-90 LN DESCRIPTION

This authentic and high performance gas work steamer with blower is perfect for all Asian cuisine kitchens and catering facilities.

SPECIFICATION

Dimensions (WXDXG)	900x900x750/1200mm
Gas Power	42kw
Gas inlet R1" Water inlet	R3/4" Drain 1/2" Rp 1/4" Rp 1"
Gas Connection Pressure	G20 20 mbar
Gas Connection Pressure	G30/31 28-30 mbar
Ignition	Electric

GAS 3 DECK STEAMER CABINETS NGSCD 9 90

DESCRIPTION

The Nayati range of authentic Asian cuisine steamer cabinets with blowers feature three models. The NGSCD 9 - 100 is CE approved and therefore suitable for the UK market. All other models are only suitable for countries where CE approval is not required.

SPECIFICATION

MODEL	NGSCD 9 90
Dimensions (WXDXH)	900 x 900 x 1895 mm
Gas power	56 kW
Electrical Power	190 w
Drain	1/2" Rp 1" / Rp 1/2"
Gas inlet pipe	R 3/4"
Water inlet pipe	R 1/2"
Gas connection pressure	G20 20 mbar G30/31 28-37 mbar



GAS RANGE COOKER / COMMERCIAL / WOK NGKB 22-90

DESCRIPTION

Double Gas Work with soup warmer with premix engine burner. Top panel constructed with deep drawn dome for both the wok and the soup warmer. Includes wok holder and wall-mounted faucet. Lever is positioned at knee level for ergonomic operation of an oriental. Compatible installation with others 125 wok range series.

PRE-RINSE UNIT & HOSE REEL



EX-1DP00-H PRE-RINSE UNIT:

Single lever deck mount faucet, 24" riser, 44" flexible, stainless steel hose, high flow spray valve, 6" wall bracket & 18" flexible supply hoses w/ check valves



5F-1SLX05

Faucet, single hole, 5-1/2" swivel goose-neck



EX-1DP12-H PRE-RINSE UNIT:

Single lever deck mount faucet, add-on faucet, 12" swing, nozzle w/ full flow aerator, 18" riser, 44" flexible stainless steel hose, high flow spray valve, 6" wall bracket & 18" flexible supply hoses w/check valves



5F-8DLX05

Faucet, 8" centers, deck mount, 5" spout



EX-6WP00-H PRE-RINSE UNIT:

Single lever wall mount base faucet, 12" swing, 44" flexible, 2 saddleback cove/ p.o. box 1088, stainless steel hose, high flow spray valve, 6" wall bracket & 1/2" male



5F-4CWX12

Equip 4" c/c deck mount workboard fct w/12" swing nozzle, 4" wrist action handles



B-0113-B PRE-RINSE UNIT:

Easy Install single hole deck mount mixing faucet, quarter, turn eterna cartridges w/ spring checks, lever handless, 44" flexible, stainless steel hose, 1.15 gpm spray valve, 6" wall bracket & flexible stainless steel supply hoses



5F-8DLX12

Faucet, wall mount, 8" centers, 12" swing nozzle



B-3950 WASTER DRAIN VALVE:

Twist handle, 3-1/2" x 2" & 1-1/2" adapter (replaces b-3912 & b-3916)



B-0133-B PRE-RINSE UNIT:

Easy Install 8" wall mount mixing faucet, quarter, turn eterna cartridges w/ spring checks, lever handless, 44" flexible, stainless steel hose, 1.15 gpm spray valve, 6" wall bracket & 1/2" npt female inlets



5HR-232-01 OPEN HOSE REEL

Black powder coated steel, open hose reel w/ø3/8" x 35" hose & high flow spray balbe

5HR-232-01 OPEN HOSE REEL

Black powder coated steel, open hose reel w/ø3/8" x 35" hose & high flow spray valve



Striving for Excellence

OUR BRANDS

FROSTPRO[®]

Hospitality Cooling Experts

Exclusive Refrigeration Equipment

DRAINPRO[®]

Commercial Drainage Solutions



OFFICE & SHOWROOM

49, Chirag Diamond Estate, Beside Pushkar Business Park, Nr. D-Mart, Bapunagar,
Ahmedabad-24, Gujarat (India).

WORKS - Bakrol Bujrang, Ahmedabad, Gujarat 382433.

EXPERIENCE CENTER

G.F. Shop No. 11 & 12, Swati Clover, Near Shilaj Circle, Beside Yanki Sizzlers,
S.P. Ring Road, Thaltej, Ahmedabad, Gujarat 380054 (INDIA)

📧 sales@janshaktiindia.com | projects@janshaktiindia.com

🌐 www.janshaktiindia.com

☎️ +91 9574001797 | 9265045532 | 9974951795 | 8488851795

To know more
about us





Striving for Excellence

The background of the cover is a photograph of a professional kitchen. It shows stainless steel countertops, a sink, a range hood, and various kitchen equipment. The image is overlaid with large, abstract geometric shapes in orange, red, and blue. The text 'Finest Professional Kitchen Equipment & Solutions' is written in white, sans-serif font on a dark blue background that covers the right side of the image.

Finest
Professional
Kitchen
Equipment
& Solutions

PRODUCT BROCHURE

www.janshaktiindia.com



Company Overview

Incorporated almost half a century ago, Janshakti Industries has since gone from being just a Kitchen Equipments Provider to a Total Commercial Kitchen Equipment manufacturer & solution provider company. Driven by the determination to serve the needs of the whole "HO-RE-CA" sector, "Janshakti Industries" has today become a synonym to "Trust".

Over the time span Janshakti Industries had crafted numerous commercial kitchens qualifying satisfied results. Staying at par with latest demands and changing trends in the market, Janshakti Industries has always strived towards maximum satisfaction through innovative products and unmatched after sale services. Janshakti Industries is today fulfilling the demands of a wide range of consumers from HO-RE-CA sector, with its most advanced kitchen solutions. With finest of raw materials and the latest and innovative technologies Janshakti Industries is today manufacturing a range of diversified products which includes Preparation Machineries, Cooking Equipments, Working & Utility Tables, Fast Food Equipments, Deck Ovens, Bakery Equipments, Catering Equipments, Trolleys, Bain Marie, Dining Tables, Cold Equipments, Display & Counters Equipments, Wash Area Equipments, Dish Washers, L.P.G Gas Pipe Line Installation & Burner & Spares etc. With such an army of product range Janshakti Industries has always lived up to the expectations.

Vision

One Vision. One Team.

To be globally admired leader for planning, designing and producing finest professional kitchen equipments.
We shall be known for our, Excellent Product Quality & Innovation,
Wide service support and Quality of Operations.

Mission

Where Purpose Transforms into a Mission.

Providing a value for money product & innovative ideas for professional kitchen solutions, that can create a benchmark in HO-RE-CA sector, for the local, national and international.
To promote a dynamic work culture that encourages employees to demonstrate their best and promote the importance of ethics in their duties. To manufacture quality products that can live up to consumer's expectations.

Quality Statement

Quality is never an accident; it is always the result of high intention, sincere effort, intelligent direction and skillful execution; it represents the wise choice of many alternatives.



We Work With...

HOSPITALITY CONSULTANTS

PMC'S

ARCHITECTS / INTERIORS

CATERING COMPANIES

CHEFS

HVAC CONSULTANTS

Infrastructure

Our state-of-the-art shop floor is well equipped with modern machineries for outstanding results with superior finish.



Laser Cutting Machine



CNC Bending Machine



TIG/MIG Welding Machine & many more



Product Designing Facilities



Laser Welding Machine



Stud Welding Machine



Low Pressure PUF foam filling machine



Well Trained Project Team



Dedicated Service Team



Enterprise Level ERP



Experience Centre (1500 Sq. ft.)



Fast Food Equipment Mfg. (3000 Sq. ft.)



Manufacturing Unit (12000 Sq. ft.)



Office & Showroom (5000 Sq. ft.)



Service (2500 Sq. ft.)



Project Cycle

For years Janshakti Has been known for long term relationship & tune by bagging repeat orders / references.



Industries we serve



Hotels



Restaurants



Industrial
Corporates



Institutes



Hospital



Central Kitchen



Cloud Kitchen



Food Courts



Bakeries



QSR

Why Janshakti Industries?

Commercial kitchen equipments are basically capital goods or long terms investment which will last for decades. Keeping this thought in mind we at JANSHAKTI we believe to deliver exceptional quality products with value for money.



LEGACY OF MORE
THAN 50 YEARS



STATE OF ART
INFRASTRUCTURE
AND FACILITY



HIGHLY TRAINED
PEOPLE



CLIENT
SATISFACTION



TRUST AND
TRANSPARENCY



VALUE FOR
MONEY



GREAT AFTER
SALES SUPPORT



TOTAL TURN
KEY SOLUTIONS



TIMELY
DELIVERY



HIGH QUALITY
PRODUCT



STURDY & DURABLE
STRUCTURING



QUALITY STEEL
GAUGE



IN HOUSE PRODUCT
DESIGN STUDIO*



CONTINUOUS
IMPROVEMENT
AND INNOVATION

Company Milestone

2022

Inaugurated JANSKAKTI Xperience Center @ Shilaj, Ahmedbad with exclusive brand tie ups

2021

Introduce new well design commercial drench product under brand "Drainpro"

2020

Introduce new well design range of refrigeration equipment under brand "Frostpro"

2019

Upgraded & Increased our production capacity by setting up new state of the art manufacturing facility in Bakrol & owned Laser Cutting & Welding Machine

2018

"Kitchen Planet" an exclusive kitchen equipment showroom started by Janshakti Industries.

2017

Mr. Parth P. Panchal after his graduation joined Janshakti Industries added further wing to company.

2016

Renovated entire manufacturing facility and added C.N.C. Bending Machine.

2011

Mr. Tejas P. Panchal after graduating joined Janshakti Industries with his core interest to develop & grow company systematically

2012

Started new unit "Janshakti Enterprise" dedicated for manufacturing excellent Fast Food Equipments.

2010

Started manufacturing Refrigeration Equipments

2008

Janshakti Industries was undertaking entire kitchen projects and positioned itself as quality & ethical manufacturer

2009

Upgraded our machinery from manual to hydraulic based Bending & Shearing machines

1997

Company started manufacturing its revolutionary product "Pulveriser Gravy Machine" in house.

1988

Started LPG Gas Line Systems Installations

1987

Started LPG Burners & Gas Ranges Manufacturing with Superior Quality & Finish

1980

Started manufacturing Conventional Stone Base Wet Grinder as 1st Equipment

1985

• Mr. Pravin M. Panchal joined JSMW and started working at Workshop while ongoing studies with vision to do excellent & quality work in company
• 1st Electric Dosa Hot Plate & Chapati Hot plate were developed

1992

Company incorporated as "Janshakti Industries" at new owned workshop in Bapunagar, Ahmedabad

1965

Small workshop started on lease by Mr. Manibhai Panchal in Shahpur, Ahmedabad with name J.S.M.W as Janshakti Sheet Metal Works

Visit our showroom



@BAPUNAGAR

VISIT OUR **SHOWROOM**
AND EXPERIENCE TO ENSURE THAT
YOU GET THE BEST IN CHOICE
INNOVATIVE PRODUCTS!!

Visit our Experience Center



**VISIT OUR EXCLUSIVE
EXPERIENCE CENTER
BEFORE STARTING YOUR DREAM KITCHEN PROJECT**

Our Customers

Restaurant / Fast Food / Bakery



Hotels / Clubs / Resorts / Malls



Corporate / Industrial / Educational



Hospital Canteens



Brands Associated with us



We will always be
happy to serve you

After Sales Service

Great after sales service is always top priority for our customers. For more than 45 years in the industry we had always stayed ahead of other by understanding clients need & providing excellent services.

JANSHAKTI INDUSTRIES is more likely recommended by our customers to others. We always take proud of that.

To provide services seamlessly, we do have dedicated after sales service number where team of professionals take care of the matter diligently. As company is growing dynamically, we are spreading our geographical boundaries of our technical team to provide faster services.

Give us call now ☎ +91 957400 1800

Timing 10.00 am - 7.00 pm

or write us at ✉ service@janshaktiindia.com

We are also offering

“Annual Maintenance Contract” & revolutionary
“Prepaid Service Scheme” with ultimate
on time approach with most economical prices.

Call now and get your AMC or PSS done.





MASTER-BROCHURE



COMPANY PROFILE



DRAINPRO



FROSTPRO



PULVERISER MACHINE



SERVICE CONTRACT



IMPORTED BRANDED



FAST FOOD EQUIPMENT



BAKERY EQUIPMENT



CATERING EQUIPMENT



SS WIPER



VISICOOLER-DEEFPREEZER



WATER COOLER

PROJECT GALLERY	01
ISLAND COOKING BLOCK	03
PRIME COOKING EQUIPMENT	05
WORK TABLES	15
OTHER EQUIPMENT	18
DRAINPRO	19
FROSTPRO	20
FAST FOOD EQUIPMENT	21
FOOD WARMING SYSTEM	22
BAIN MARIE / SERVERY LINE	23
TROLLEY	26
PRE-PREP EQUIPMENT	28
HAND WASH SINK	30
DINING TABLE	31
BAR COUNTER	32
LIVE FOOD COUNTER	33
DISH WASH AREA	34
RACKS	37
KITCHEN VENTILATION SYSTEM	38
SS FLOOR WIPER	40

PROJECT GALLERY





FOR MORE IMAGES & VIDEOS PLEASE VISIT OUR WEBSITE





ISLAND COOKING BLOCK

COOKING IS AN ART AND WE ARE THE CONNOISSEURS

Types of Island Cooking Blocks

Centre Island Block

Can be operated from all sides







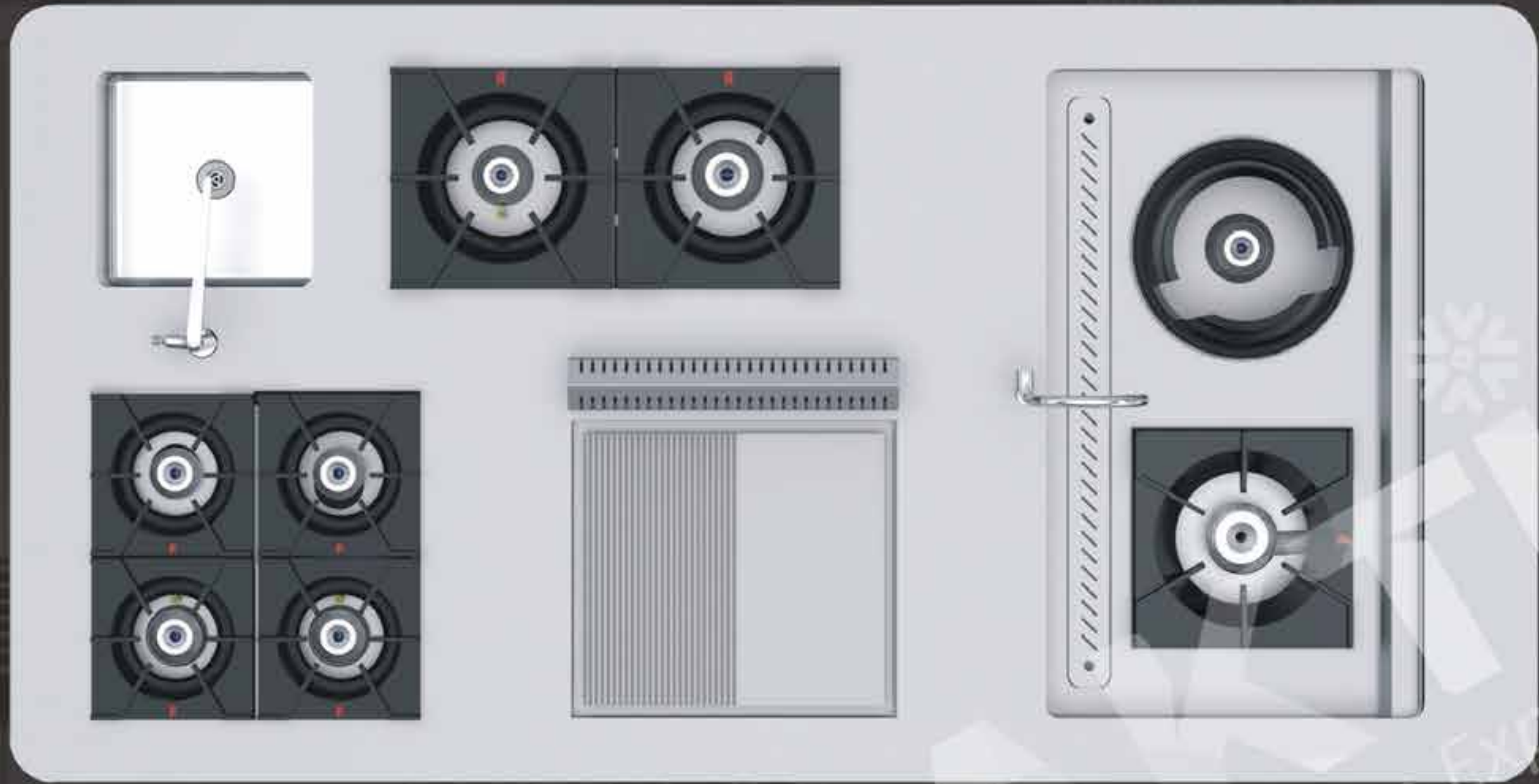









One Sided Block

It can be operated from one side only

- ▶ Island Cooking Block is usually used for live / open kitchens.
- ▶ It enables chefs to cook varieties of cuisines on single platform.
- ▶ Entire design is tailor made as per requirement.
- ▶ Workmanship that excel beyond expectations, Performance that deliver efficiently.



VARIETIES OF FUNCTIONS WE CAN CHOOSE FROM BELOW MENTIONED

 Neutral Cupboard With Hinged Door	 Neutral Cupboard Sliding Door	 Open Cupboard	 Hot Ventilated Cupboard	 Gastronorm Cupboard	
 Gastronorm Drawers	 Sink	 Teppan Yaki	 Pasta Cooker	 Electric Fryer	
 Bain Marie	 Gas Open Burners Under Cast Iron	 Gas Wok	 Static Oven	 Plain Work Top	 Over Head Shelves

PRIME COOKING EQUIPMENT

Cooking Equipments Are Very Basic Requirement Of Any Kitchen. It Is Used To Cooked Varied Recipes And Cuisines. Range Of Equipments Include Like Cooking Range, Bulk Cooking Range, Hot Plate, Roti Puffer, Tandoor, Steamer, Etc.



FEATURES OF OUR PRIME COOKING EQUIPMENTS



Robust All Stainless-Steel Structure



Quality Spares & Parts



Engineered for rugged usage



Well Designed & Heavy-Duty C.I. Pan Support*



Janshakti Brand Efficient Burners



High quality manifold system to enhance safety.



Full Length Cut Free Steel Drip Tray*



Designed Cross Air Ventilation



Surround Polished Technology for Hot Plates*



Gas Line Cavity for Utilities



All burners with Pilot for Gas Saving*

INDIAN COOKING RANGE

SINGLE BURNER RANGE



TWO BURNER RANGE



THREE BURNER RANGE



PRODUCT NAME	STANDARD SIZE (with C.I. - 350x350)	STANDARD SIZE (with C.I. - 400x400)	ALL BURNERS WITH PILOT
Single Burner Range	516 x 600 x 850 + 150	585 x 600 x 850 + 150	YES
Two Burner Range	1125 x 600 x 850 + 150	1140 x 600 x 850 + 150	YES
Three Burner Range	1550 x 600 x 850 + 150	1700 x 600 x 850 + 150	YES

SPECIAL FEATURES:

- ▶ All designed stainless steel square tube structure for longer product life
- ▶ Engineered cross air ventilation & cross structuring.
- ▶ P Type design for hassle free installation
- ▶ Heavy Duty Janshakti own Brand highly durable Burners & Copper Tubes ensures GAS SAVING & Safety.

NOTES:

- ▶ We prefer Standard Size with C.I. 350 x 350 is ideal.

CONTINENTAL COOKING RANGE

FOUR BURNER RANGE



FOUR BURNER RANGE WITH STATIC OVEN



PRODUCT	STANDARD SIZE (With C.I. - 300 x 300)	STANDARD SIZE (With C.I. - 350 x 350)
Four Burner Range	750 x 750 x 850 + 150	850 x 850 x 850 + 150
Oven Chamber Size*	400 x 250 x 300	450 x 300 x 300
Elec. KW For Oven	2.1 KW	2.4 KW

NOTES:

- ▶ Electric Ovens are optional with Cooking Range
- ▶ Ovens are electric operated, thermostatically controlled and Cerawool insulated with SS Rod Shelf. Any special requirements need to be clarified prior to order.

PAN ASIAN / CHINESE / ORIENTAL COOKING RANGE

TWO BURNER RANGE (1+1)



THREE BURNER RANGE (2+1)



PRODUCT NAME	OVERALL SIZE	WOK PAN 400mm Dia.	STOCK PAN SUPPORT	FAUCET/TAP POINT
Two Burner	1350 x 800 x 750 + 300	1	1	1
Three Burner	1800 x 800 x 750 + 300	2	1	2

SPECIAL FEATURES:

- ▶ Tray Type heavy top with leakage proof design.
- ▶ All designed stainless steel square tube structure for longer product life
- ▶ Engineered cross air ventilation & cross structuring.
- ▶ P Type design for hassle free installation
- ▶ Heavy Duty Janshakti own Brand highly durable Burners & Copper Tubes ensures GAS SAVING & Safety.

NOTES:

- ▶ Standard Chinese Cooking Range comes with Tray Type Top, Back Side Drain Channel, Faucet, specially designed Wok Pan Support, Stock Pan Support, & Robust Steel Structure with Superior finish. All internal water line connection is done with G.I. pipes.

ADDITIONAL OPTIONS:

- ▶ Front Water Sprinkler System, High Pressure Blower Burner System, T&S Wok Faucet, Foot operated tap, Separate Drain Box or any other requirement of client / Consultant can be incorporated.

CHAPATI PLATE WITH PUFFER



SPECIAL FEATURES

- ▶ Surround Plate polishing technology provides superior polished plate.
- ▶ Heavy Duty Janshakti own Brand highly durable Burners & Copper Tubes
- ▶ Vertical burner distribution for even heat & GAS SAVING.

NOTES:

- ▶ Standard model includes Metal Bullet Puffer.
- ▶ C.I. Puffer or MS Plate puffer are optional.

PRODUCT NAME	OVERALL SIZE	BURNERS	HOT PLATE SIZE
Chapati Plate with Puffer	900 x 600 x 850 + 25	2+1	600 x 600 x 12 mm
	1200 x 600 x 850 + 25	3+1	900 x 600 x 12 mm

REVOLVING CHAPATI PLATE WITH PUFFER



SPECIAL FEATURES

- ▶ Mainly used @ Dining Hall, Thali restaurant & Industrial canteens for higher production.
- ▶ 12mm Thick MS Plate with superior Surround Polish Technology.

NOTES:

- ▶ In standard model it comes with plate puffer.
- ▶ Revolving Puffer & Plate puffer are installed separately by using "T" joint.

PRODUCT NAME	OVERALL SIZE	ROUND PLATE DIA.	PLATE PUFFER SIZE
Revolving Plate with Puffer	1200 x 750 x 750	750 mm x 12 mm	450 x 600 x 750
	1500 x 900 x 750	900 mm x 12 mm	600 x 600 x 750

DOSA HOT PLATE



PRODUCT NAME	OVERALL SIZE	BURNERS	HOT PLATE SIZE
HOT PLATE	900 x 600 x 850 + 25	3	900 x 600 x 12 mm
	1200 x 600 x 850 + 25	4	1200 x 600 x 12 mm

GRIDDLE HOT PLATE

GRIDDLE HOT PLATE

PLAIN



GRIDDLE HOT PLATE

SERRATED



PRODUCT NAME	OVERALL SIZE	BURNERS	HOT PLATE SIZE
GRIDDLE	600 x 750 x 850 + 150	2	500 x 625 x 15 mm
HOT PLATE	750 x 750 x 850 + 150	3	650 x 625 x 15 mm
	900 x 750 x 850 + 150	3	800 x 625 x 15 mm

SPECIAL FEATURES

- ▶ Surround Plate polishing technology provides superior polished plate.
- ▶ Heavy Duty Janshakti own Brand highly durable Burners & Copper Tubes
- ▶ Vertical burner distribution for even heat & GAS SAVING.
- ▶ Serration / Ribbed / Grill marks option is available upon request.
- ▶ In griddle hot plate unique oil collection tray has been provided.

TANDOORS

SS / MS SQUARE BOX TANDOOR



SS / MS DRUM TANDOOR



ELEC. DEEP FRYER

600 x 750 x 850 + 150



ELEC. KADAI FRYER

Available in 450, 550, & 600 mm dia. kadai



SIZZLER PLATE RANGE

450 x 600 x 850 + 150



LAVA GRIDDLE RANGE

600 x 750 x 850 + 150



BULK COOKING RANGE

► Stock pot stoves are very simple but very important equipment for food preparation in day-to-day operations. It is majorly used for bulk cooking preparations. Heavy Potvessels are used on top of stove. Janshakti made STOCK POT STOVE ensures engineered & designed structure for rugged use, superior finish and full-length drip tray & Pilot burner are standard part of equipment.

► Highly Durable, Very Reliable...Its JANSHAKTI

STOCK POT RANGE



POT FILLER FAUCET



► Pot Filler faucets are used to fill water in Pot Vessels during cooking preparation of food delicacies. It makes water filling very easy, hassle free and helps in maintaining hygiene & cleanliness.

Overall size (mm)	Pan Support size (mm)
516 x 700 x 450	400 x 400
700 x 700 x 450	450 x 450
850 x 850 x 450	600 x 600

TWO BURNER RANGE

WITH WATER TAP & DRAINAGE CHANNEL
1500 x 750 x 600 + 300



TILTING BOILING /BRAT PAN

TILTING BOILING PAN



KEY FEATURES

- ▶ Boiling Pan is suitable to boil, steam, poach, braise or simmer various delicacy.
- ▶ Single wall lid balanced by means of a hinge with front handle.
- ▶ Well emptying by 2" valve with handle. (Optional)
- ▶ Large capacity allows for preparation of large amounts of food.
- ▶ Easy to clean and maintain.
- ▶ Maintains flavour and nutrients.
- ▶ Tilt design allows for more convenient transfer of foods to serving pans and storage containers.
- ▶ Unit to have Nylon Adjustable feet with height adjustment up to 15mm.
- ▶ Integrated water faucet as standard.

Liter Capacity	Overall Size (mm)
60	1100 X 900 X 900
100	1200 X 900 X 900
150	1300 X 900 X 900
200	1350 X 1000 X 1000

TILTING BRAT PAN



KEY FEATURES

- ▶ Cooking surface for roasting, browning, stewing, preparation of sauces, sautéing, boiling and braising. Manual tilting mechanism to facilitate pan emptying.
- ▶ Smooth large surfaces, easy access for cleaning.
- ▶ Unit to have Nylon Adjustable feet with height adjustment up to 15mm.
- ▶ Stainless steel single skin lid is balanced and has strong stainless steel AISI 304 hinges and an ergonomic front handle.
- ▶ Integrated water faucet as standard.

Liter Capacity	Overall Size (mm)
60	1300 x 900 x 900
80	1350 x 900 x 900
100	1400 x 900 x 900
120	1450 x 1000 x 900

STEAMER

KHAMAN STEAMER

AVAILABLE IN 6, 8, & 10
TRAYS CAPACITY

VATI DAL KHAMAN STEAMER

AVAILABLE IN 6, 8, & 10
TRAYS CAPACITY

LIVE DHOKLA STEAMER

AVAILABLE IN 6, 8, 10, 12
TRAYS CAPACITY

IDLI STEAMER

Available in 54, 72, 96, 120,
180 Idlis Capacity

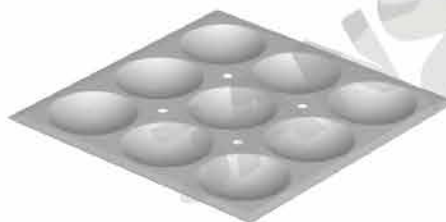
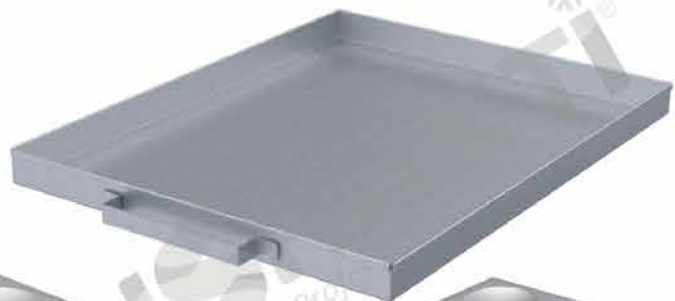

TRAY TYPE	SIZE (MM)
LIVE DHOKLA	350 x 450 x 12
DHOKLA TRAY	350 x 450 x 25
VATI DAL	350 x 450 x 38
NYLON KHAMAN	350 x 450 x 60
9 IDLI TRAY	300 x 300
12 IDLI TRAY	350 x 450

WORK TABLES

- ▶ Work tables or Work Tops are essential part of any HO-RE-CA kitchens. Work tables can be used in various formats as per clients needs like Side Tables, Spreader Table, Service & Beverage Stations, Pick Up Tables, etc.
- ▶ For layman it may look just table, but from technical perspective it is very important to be manufactured correctly.



FEATURES OF WORK TABLES

- ▶ All Laser Cut & amp CNC Bending manufacturing.
- ▶ Superior Finishing with Burr free edges.
- ▶ Designed all SS Square Tube Inside Top Structuring. No MS Used.
- ▶ Inverted Hat Type Stiffeners with both ends closed leaving no space for roaches.
- ▶ Aligned Back Splash with Bottom levelers
- ▶ Quality hardware components used for cabinets & drawers.
- ▶ Sink available in both Die Press & Welded.

WITH 1 U/S.)



WITH 2 U/S.)



WITH SINK



MOBILE TABLE



CABINET TABLE WITH DOORS



TABLE WITH PLATE WARMER



WITH OVER HEAD SHELF



STONE TOP TABLE



PICK UP WITH BAIN MARIE



PICK UP COUNTER WITH CABINET



WALL SHELVING SYSTEM

SINGLE



CABINET TYPE



BOX TYPE



POT WALL SHELF



ONION / POTATO CAGE

Heavy square tube structure with thick wire mesh rod and tapered bottom with collection latch.
600 x 600 x 900



DUNNAGE RACK

1200 x 600 x 200



STEEL GROCERY BIN

Available in 35, 50, 100, 150 Kgs Storage Capacity



GROCERY BIN



PLATE WARMER

50 Plate Capacity



SS DUSTBIN – REGULAR

Available in 60 & 90 Ltrs Capacity,



SS DUSTBIN – SQUARE SWING

Available in 90 & 110 Ltrs Capacity



DRAINPRO provides industrial/ commercial drainage solution for the industries where hygiene is essential. DRAINPRO has product range manufactured from non corrosive stainless steel like Drain Trough, Drain Cover, Grease Trap Chamber available in different sizes and models. DRAINPRO is extensively designed and manufactured by JANSHAKTI INDUSTRIES with state of the art manufacturing facility. Entire fabrication is done inhouse using Laser cutting machine, CNC bending with Italian tooling, Laser welding, & Imported assembly table with jigs & fixture.

DRAIN THROUGH



TRENCH COVERS

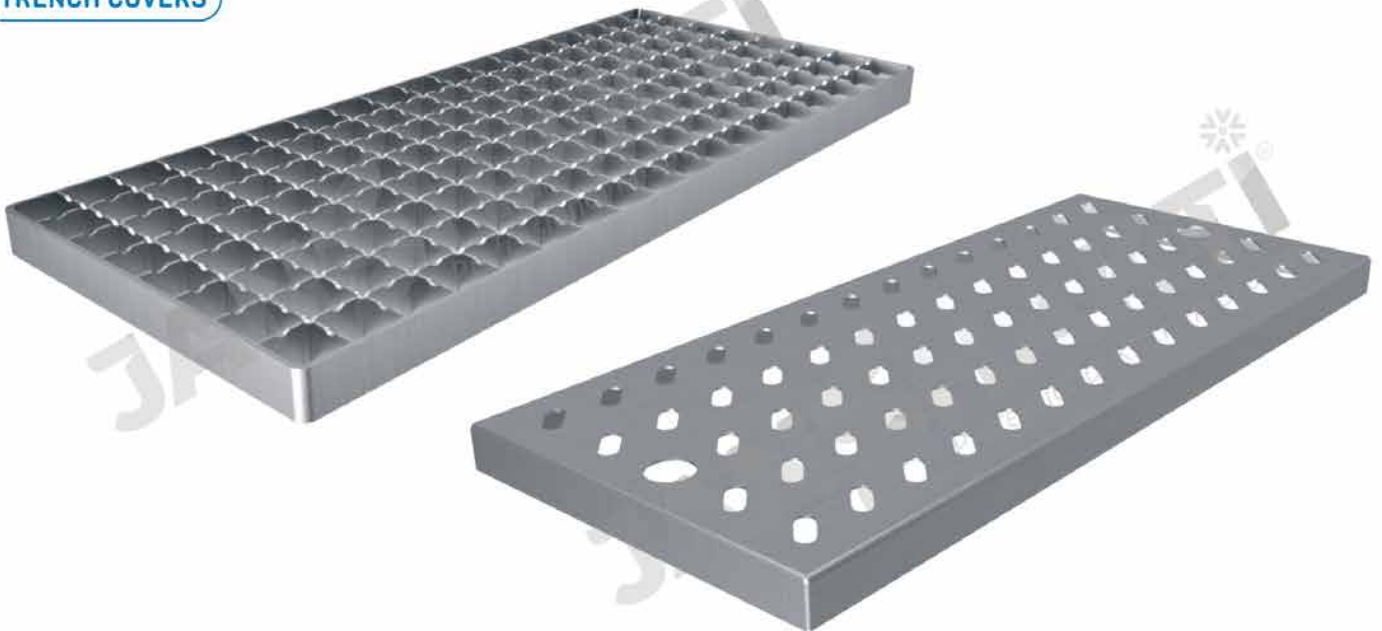

TO KNOW MORE ABOUT DRAIN PRO
DRAINAGE SOLUTION DOWNLOAD OUR BROCHURE



FrostPro is speciality brand developed by JANSHAKTI INDUSTRIES under which all engineered cooling equipment are developed and manufacture like UNDER COUNTERS, MAKE LINE & SALAD BAR etc.

FrostPro keeps it Fresh.

The Exclusive FrostPro refrigeration technology for any professional requirements.

UNDERCOUNTER FRIDGE



MAKELINE WITH UNDERCOUNTER FRIDGE



TO KNOW MORE ABOUT FROST PRO
HOSPITALITY COOLING SOLUTIONS DOWNLOAD OUR BROCHURE



JANSHAKTI ENTERPRISE was incorporated in 2010 with vision to manufacture world class fast food equipments with utmost quality, precision, durability and superior finishing. Since its inception all manufacturing process was done by laser cutting technology. What makes us stand apart from rest of the crowd is the hard work we put forth in delivering products with a customer centric approach in conjunction with extensive R&D, manufacturing, management and marketing. Initially it was started with handful of products and now JANSHAKTI ENTERPRISE is manufacturing more than 30+ different types of fast food equipments with strong dealer network across India. Driven by the determination to serve the needs of the whole "QSR sector, "Janshakti Enterprise" has today become a synonym to "Trust & Quality".

Designed to make your
Everyday
Life Easier

PIZZA OVEN



SANDWICH GRILLER



DEEP FRYER



FOOD WARMER



TO KNOW MORE ABOUT FAST FOOD EQUIPMENT
SOLUTIONS DOWNLOAD OUR BROCHURE



Electric food warmers are very important piece of equipment for pick up operations in kitchen areas. It helps in keeping cooked food warm until it is picked up for guests. Food warmers are very helpful during monsoons & winters.

IR BULB WARMER



IR bulb warmers has separate IR Lamps which radiates instant heat when required. It comes with separate on/off toggle switch which provides great flexibility over operating.

TECHNICAL DETAILS

SIZE	1050 x 225 x 215	1350 x 225 x 215	1650 x 225 x 215
ELEC.	4 x 250w	5 x 250w	6 x 250w

IMPORTED TUBE HEATER

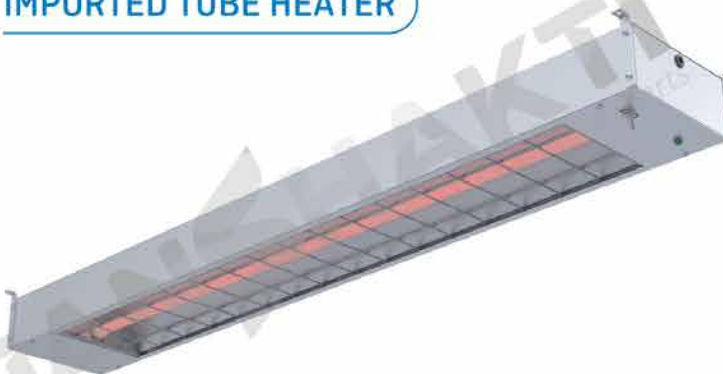

Imported Tube heaters are full length glass tube heater which radiates heat only bottom of tube and comes with cold zone. These heaters take pre heating time of 4-5 mins which is faster over traditional coil heaters. It comes with safety grid @ bottom. It comes with single on/off toggle switch.

TECHNICAL DETAILS

SIZE	1050 x 200 x 100	1350 x 200 x 100	1650 x 200 x 100
ELEC.	1000W	1000W	1000W

ELECTRIC COIL / HEATER



Electric Coil food warmers are most basic and traditional warming system used. It radiates powerful heating over other warming systems in market. It is manufactured in SS double skin housing with insulation and safety grill @ bottom. It comes with thermostat controller and on/off toggle switch. It takes pre heating time of 15-25 mins.

TECHNICAL DETAILS

SIZE	1050 x 200 x 100	1350 x 200 x 100	1650 x 200 x 100
ELEC.	1000W x 2	1000W x 2	1000W x 2
TEMP.	30-110 Degrees.		

BAIN MARIE / SERVERY LINE

Bain marie is used to keep cooked food warm. it is usually used at places like industrial canteens, staff cafeterias, pantry, thali style restaurant & fast food restaurants. it helps in serving faster & warm food to guests.



FEATURES OF BAIN MARIE



High Quality Electrical Components



Specially designed cavity tank



AISI 304 Grade 0.8mm GN Pan Containers



Elevated Tank design for ease of operation



Empty Tank Cut off sensor (Optional)

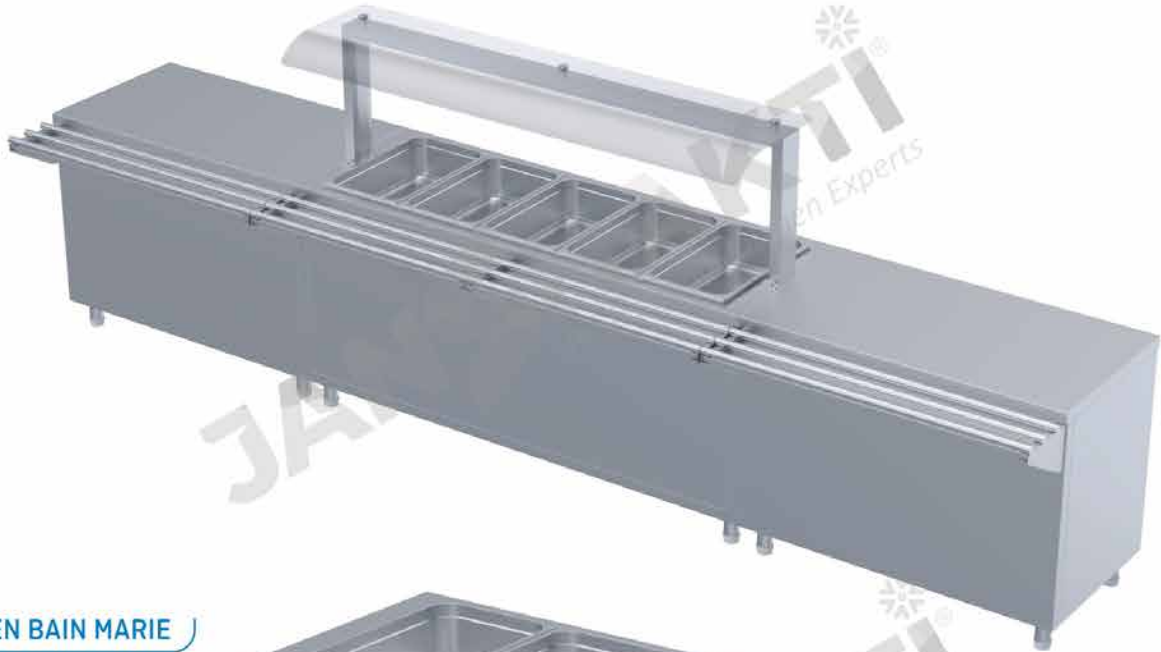

CANTEEN BAIN MARIE

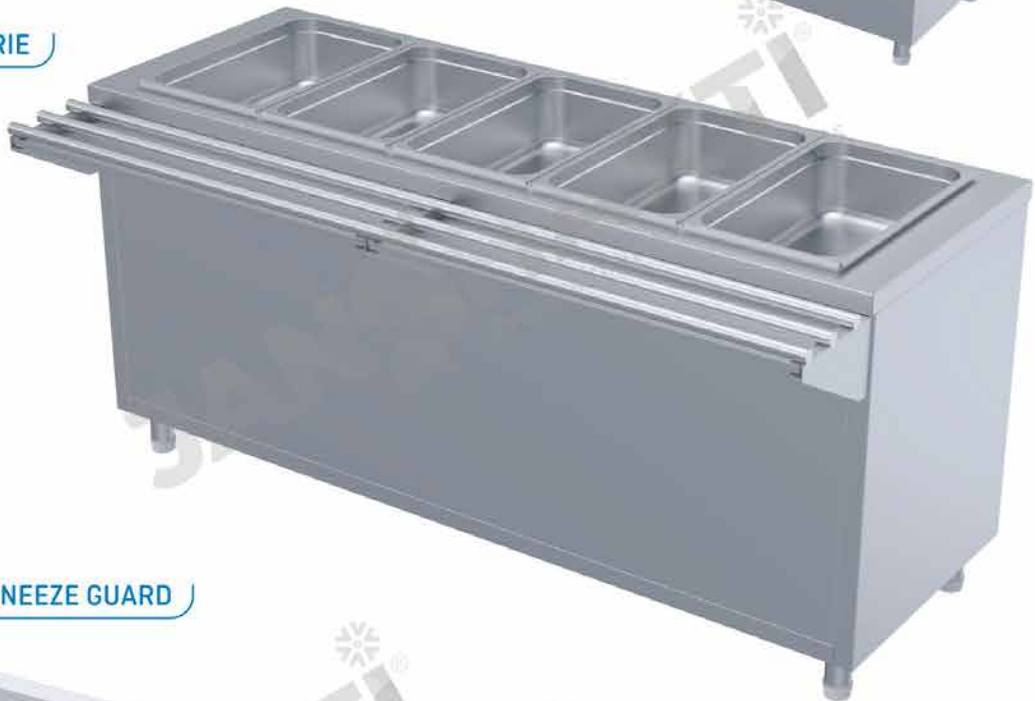

BAIN MAIRE WITH SNEEZE GUARD



NEUTRAL TABLE



BAIN MAIRE WITH STAND



ROUND CONTAINER BAIN MAIRE



CONTAINER SIZE

GN PAN TYPE	SIZE (MM)	LTR CAP.
1/1 x 150 mm	525 x 325 x 150	20 Ltrs.
1/2 x 150 mm	325 x 260 x 150	9 Ltrs.
1/3 x 150 mm	325 x 175 x 150	5 Ltrs.
round std.	225 Dia x 200 ht.	5 Ltrs.
round jumbo	265 Dia x 225 ht.	7 Ltrs.

MINI BAIN MARIE



MINI BAIN MARIE WITH CANOPY



PRODUCT NAME	GN SIZE	OVERALL SIZE	PAN CAP.	ELEC.
MINI BM	1/2 x 150mm - 3 Pcs	840 x 370 x 265	9 Ltrs x 3 Pans	2 KW/ 230v
MINI BM	1/3 x 150mm - 3 Pcs	570 x 370 x 265	5 Ltrs x 3 Pans	2 KW/ 230v
MINI BM With Canopy	1/2 x 150mm - 3 Pcs	840 x 370 x 265 + 225	9 Ltrs x 3 Pans	2 KW/ 230v
MINI BM With Canopy	1/3 x 150mm - 3 Pcs	570 x 370 x 265 + 225	5 Ltrs x 3 Pans	2 KW/ 230v

- ▶ Heavy Duty PU Castor Wheels
- ▶ Swivel + Lockable Castors
- ▶ Corner Bumper Guards (On Applicable Models)
- ▶ Superior Finishing

SERVICE TROLLEY

750 x 525 x 850mm | 900x 525 x 850mm
AVAILABLE IN 2 / 3 SHELF



FOOD SERVING TROLLEY

Available in Elec. Warming System



MASALA TROLLEY

Available in 8, 9 or 12 Round Containers.



MASALA TROLLEY

Available in 9 or 12 GN Pans.



PLATFORM TROLLEY

900 x 520 x 850
Static load Barring: 350kg Approx



GN PAN HOLDING TROLLEY

500 x 600 x 1800mm



VEG CRATE HOLDING TROLLEY

450 x 550 x 1650mm



GLASS CRATE HOLDING TROLLEY

600 x 600 x 1500mm



LIVE COOKING TROLLEY



TEA SERVING TROLLEY



WASTE BUCKET TROLLEY

900 x 525 x 850



CLEARANCE TROLLEY FOR BANQUET



PLATE COLLECTION TROLLEY



PULVERISER MACHINE



MOTOR	POWER (KW)	CAP./HR.	SIZE (mm)
1.5 HP / 1 Ph. / 2800 rpm	1.125	50-60 Kgs.	400 x 300 x 500
3.0 HP / 3 Ph. / 2800 rpm	2.25	80-100 Kgs.	460 x 360 x 680
5.0 HP / 3 Ph. / 2800 rpm	3.75	90-130 Kgs.	460 x 360 x 680

Includes SS Safety Cover Tray, Wooden Handle, SS Sieves Jali - 2 Sets (8 Pcs)

FEATURES

- ▶ Full Stainless-Steel Structure
- ▶ Rodent Safety from bottom
- ▶ Robust Die Casted Chamber
- ▶ Rugged Stainless-Steel Blades
- ▶ Uniquely designed Hopper for feeding
- ▶ SS Collection Tray
- ▶ Ultimate quality motor with copper winding
- ▶ Quality & Branded Electrical Parts

DOUGH KNEADER

AVAILABLE IN 5,10,20,40 Kg. Capacity



VEGETABLE CUTTING - INDIAN

Available in 100Kg & 500kg Per Hour Capacity



VEGETABLE CUTTING - IMPORTED



POTATO PEELER

AVAILABLE IN 10 & 20 Kg. Capacity



WET GRINDER

AVAILABLE IN 5,7,10,15, Ltrs Capacity



TILTING WET GRINDER

AVAILABLE IN 10,15,20,25,40, Ltrs Capacity



POTATO PEELER

AVAILABLE IN 10 & 20 Kg. Capacity



BONESAW MACHINE



MEAT MINCER MACHINE



HAND WASH SINK - ROUND



HAND WASH SINK - ECLIPSE



HAND WASH SINK



HAND WASH SINK - KNEE OPERATED



HAND WASH TROUGH - WALL MOUNTED



HAND WASH TROUGH - FLOOR STANDING



* SOAP DISPENSER & FAUCET IS OPTIONAL

DINING TABLE - FOLDING STOOL

Available in 4, 6, 8 Seater Capacity

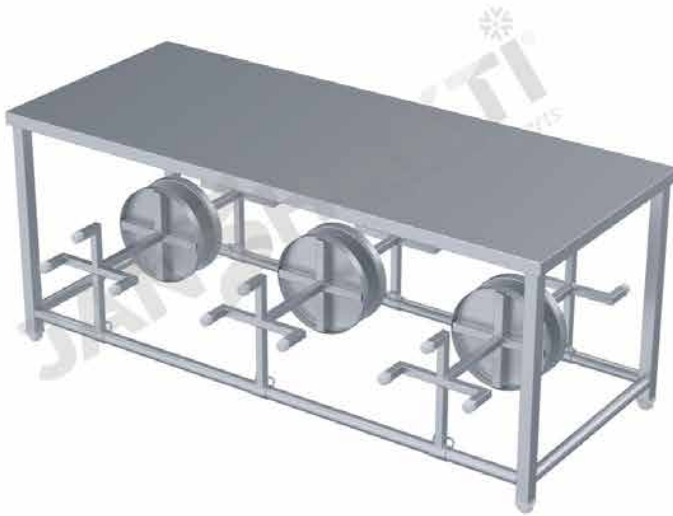

DINING TABLE - FIX STOOL

Available in 4, 6, 8 Seater Capacity



DINING TABLE WITH BENCH

Available in 4, 6, 8 Seater Capacity



STANDING TABLE

600 x 600 x 1050 | 750 x 750 x 1050



BAR COUNTER 1



► We can manufacture bar counter as per client's / consultant requirement.

BAR COUNTER 2



BAR COUNTER 3



BAR COUNTER 4



VADA PAV / DABELI COUNTER



CHAAT COUNTER



SANDWICH COUNTER



PANI PURI COUNTERS



SINGLE SINK UNIT

585 x 600 x 850 + 150



TWO SINK UNIT

1100 x 600 x 850 + 150



THREE SINK UNIT

1550 x 600 x 850 + 150



POT WASH SINK

900 x 600 x 850 + 150



SOILED DISH TABLE

1050 x 650 x 850
1300 x 650 x 850



SOILED DISH TABLE WITH O/H GLASS RACK

1050 x 650 x 850 + 450
1300 x 650 x 850 + 450



SOAKING TANK

600 x 600 x 600



SINK STRAINER



ENTRY TABLE



EXIT TABLE



ROLLER TABLE



HOSE REEL

Available in 35 feet & 50 feet length



PRE-RINSE SPRAY UNIT

GLASS CRATE

500 x 500 x 100



DISH CRATE

500 x 500 x 100



SS STORAGE RACK

4 Shelves - 1125 x 450 x 1550 mm
5 Shelves - 1125 x 450 x 1800 mm



MS STORAGE RACK

4 Shelves - 1125 x 450 x 1550 mm
5 Shelves - 1125 x 450 x 1800 mm



PLATE RACK / COLD ROOM RACK

4 Shelves - 1125 x 450 x 1550 mm
5 Shelves - 1125 x 450 x 1800 mm



POT RACK

1050 x 585 x 1550 mm
1450 x 585 x 1550 mm



EXHAUST HOOD



VAPOR HOOD



Janshakti undertakes turnkey projects for
Commercial Kitchen Ventilation System
Exhaust / Fresh Air Duct works

ISLAND HOOD



COMPENSATING HOOD



FOR CLEAN & HYGIENIC FLOOR

Floor Wiper - Heavy Duty is highly durable product for wiping wet floor. Made from Stainless Steel AISI 304 grade from heavy gauge material. Replaceable Wiper strip is made from industrial grade rubber for long lasting use.

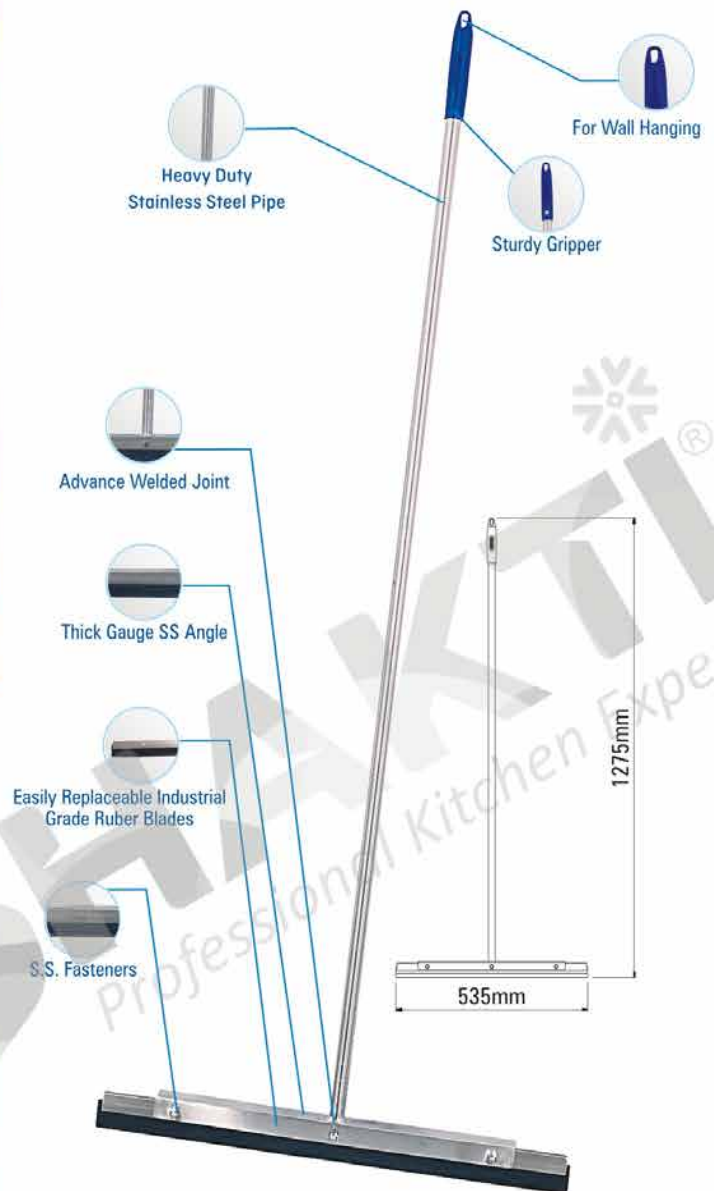

PRODUCT FEATURES COMPARISON TABLE

JANSHAKTI FLOOR WIPER	ORDINARY FLOOR WIPER
Made from Stainless Steel	Made from Iron
Thick Gauge Pipe	Low Gauge Pipe
Long Life & Highly Durable	Short Life & "Use and Throw"
Saves Cost in Longer Run	Proves Costly in Longer Run
Industrial Grade Rubber Blades	Domestic Grade Sponge (Not even rubber)
Replaceable Wiper Blades	Non-Replaceable Wiper Blades
S.S. Fasteners	Iron Fasteners (Rust Faster)
Almost Unbreakable	Easily Breakable

JANSHAKTI®

Professional Kitchen Experts

Striving for Excellence

— OUR BRANDS —

FROSTPRO®

Hospitality Cooling Experts

Exclusive Refrigeration Equipment

DRAINPRO®

Commercial Drainage Solutions

Office & Showroom : 49, Chirag Diamond Estate, Beside Pushkar Business Park, Nr. D-Mart, Bapunagar, Ahmedabad-24, Gujarat (India).

Works : Bakrol Bujrang, Ahmedabad, Gujarat 382433.

Experience Center : G.F. Shop No. 11 & 12, Swati Clover, Near Shilaj Circle, Beside Yanki Sizzlers, S.P. Ring Road, Thaltej, Ahmedabad, Gujarat 380054 (INDIA)

📧 sales@janshaktiindia.com | projects@janshaktiindia.com

🌐 www.janshaktiindia.com

📞 **+91 9574001797 | 9574001796 | 9624866366 | 8488851795**
92650 45532 | 99745 37373



HOTREMAI

To know more about us

